

**00 91 04      ADDENDUM NUMBER 04**

**Owner:**                    City of Lucas

**Project:**                    W Lucas Rd Reconstruction and Widening

**Project No.:**                045-026

**Addendum No.**         04

**Addendum Date:**       July 1, 2026

---

**The following additions, deletions, modifications, or clarifications shall be made to the appropriate portions of the Contract Documents. Offerors must acknowledge receipt of this Addendum in the space provided on the Bid Form.**

---

<b>Approved by:</b> <u>Freese and Nichols, Inc.</u>
<b>Name:</b> <u>Sidney Green Jr., PE</u>
<b>Date:</b> <u>July 1, 2026</u>

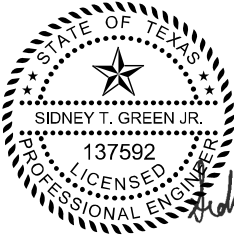

*Sidney Green Jr.*  
07/01/2026

**Freese and Nichols, Inc.**  
Texas Registered Engineering Firm  
F-2144

**ARTICLE 1 – ADDENDUM**

- 1.01 Amend the Contract Documents
  - A. Make the additions, modifications, or deletions to the Contract Documents described in this Addendum.
- 1.02 Acknowledge Addenda
  - A. Acknowledge receipt of this Addendum in the Bid Form submitted for this Project. Failure to acknowledge receipt of this addendum in the Bid Form may render the Bid as non-responsive and serve as the basis for rejecting the Bid.

**ARTICLE 2 – BID REQUIREMENTS**

- 2.01 Section I “Notice to Bidders”
  - A. Amend Subsection 1.2 as follows:
    - 1. The time for receipt of Bids has been changed to **Tuesday, July 21<sup>st</sup>, 2026 at 2:00 P.M. Central Time.**
    - 2. The location for the receipt of Bids is unchanged.
  - B. Delete “Notice to Bidders” and replace it with “Notice to Bidders” included with this Addendum.

**ARTICLE 3 – SPECIFICATIONS**

- 3.01 Add the following Specification Sections:

Section	Section Title
SS7122	Sanitary Sewer

- 3.02 Delete the following Specification Sections:

Section	Section Title
15073	High Density Polyethylene (HDPE) Pipe and Fittings

**ARTICLE 4 – DRAWINGS**

- 4.01 Replace the following Drawings:

Replace Drawing	
Drawing No.	Drawing Title
219	Force Main Plan and Profile (Sheet 5 of 12)
220	Force Main Plan and Profile (Sheet 6 of 12)
227	Force Main Details (Sheet 1 of 3)
228	Force Main Details (Sheet 2 of 3)

**END OF SECTION**

DAVIS-BACON WAGE RATES

SECTION VI FORMS DUE AFTER AWARD/PRIOR TO CONTRACT EXECUTION

1. EXAMPLE FORMS

**SECTION I  
NOTICE TO BIDDERS**

**1.1 INTRODUCTION**

Section I provides general information to potential proposers on subjects such as where to submit proposals, number of copies, amendments, proprietary information designation, and other similar administrative elements.

**1.2 SUBMISSION OF BID/PROPOSAL**

Electronic responses are the preferred method of receiving responses for this solicitation. However, all methods detailed in this solicitation are acceptable. All bids/proposals will be received by the City of Lucas Purchasing Office. If proposer submits a hard copy, bids/proposals shall be in one envelope clearly marked with the Bid Number on the outside of the envelope containing the bid/proposal.

**INVITATION FOR BID #045-26**

**WEST LUCAS ROAD RECONSTRUCTION AND WIDENING (Base and Add Alternative 1)**

Electronic bids/proposals are to be submitted to CivCast procurement site

Sealed bids/proposals are to be submitted to:

**CITY OF LUCAS PURCHASING  
RE: BID #045-26  
665 COUNTRY CLUB ROAD  
LUCAS, TX 75002-7651**

**NO LATE BIDS/PROPOSALS WILL BE ACCEPTED  
FACSIMILE BIDS/PROPOSALS WILL NOT BE ACCEPTED**

**Bid Deadline July 21<sup>st</sup>, 2026 2:00 P.M. Central Time**

Promptly thereafter, all Bids/Proposals that have been duly received will be publicly opened and read aloud in the Council Conference Room, City Hall.

Plans, specifications and bid documents may be downloaded for the City of Lucas website:  
<https://www.lucastexas.us/bid-postings> or procurement website, CivCast.

**1.3 PRE-BID CONFERENCE**

A **Pre-Bid Conference** will be held for the above project at Lucas City Hall, 665 Country Club Road, Lucas, TX 75002 at **10:00 A.M., (May 26, 2026)**.

#### **1.4 NUMBER OF COPIES**

Electronic submission is recommended. If the proposer chooses to submit a hard copy bid, Bidder/Proposer shall submit one (1) original set and **ONE (1)** copy of proposal documents. This will greatly facilitate the evaluation process. The proposal shall remain the property of the City of Lucas. The original copy shall be unbound and clearly marked "Original".

#### **1.5 BID/PROPOSAL INFORMATION**

All questions regarding bid/proposal preparation, selection process, specifications and interpretations of the terms and conditions of the bid/proposal shall be submitted through the procurement website, [Civcast](#). Any addenda will be issued no later than three (3) calendar days prior to the deadline for submission of bids.

#### **1.6 PREVAILING WAGE RATES**

Attention is called to the fact that the Contractor must pay labor on this project not less than the general prevailing rates of wages, which have been established for Collin County and attached herein for reference.

As stated in the *Texas Government Code*, Title 10, Subtitle F, Chapter 2258, Subchapter B:

Sec. 2258.021. RIGHT TO BE PAID PREVAILING WAGE RATES.

(a) A worker employed on a public work by or on behalf of the state or a political subdivision of the state shall be paid:

(1) not less than the general prevailing rate of per diem wages for work of a similar character in the locality in which the work is performed; and

(2) not less than the general prevailing rate of per diem wages for legal holiday and overtime work.

(b) Subsection (a) does not apply to maintenance work.

(c) A worker is employed on a public work for the purposes of this section if the worker is employed by a contractor or subcontractor in the execution of a contract for the public work with the state, a political subdivision of the state, or any officer or public body of the state or a political subdivision of the state.

#### **1.7 DISCLOSURE OF RESPONSE**

All information submitted in an accepted response must be retained by the City of Lucas for the period specified in the City of Lucas's record retention schedule created under Government Code Section 441.180, et sequitur. The information will not be returned to the respondent. The Public Information Act (PIA), Government Code Chapter 552, allows the public to have access to information in the possession of a governmental body through an open records request. Therefore, the respondent shall clearly identify in the response any confidential or proprietary information. Proprietary information identified by the respondent in the response, will be kept confidential by the City of Lucas to the extent permitted by state law. The City of Lucas merely raises the exception on behalf of the vendor. The City of Lucas takes no legal position on disclosure. The City of Lucas will use best efforts to give the respondent or the awarded vendor an opportunity to present to the Office of the Attorney General its arguments for non-disclosure of its identified confidential or proprietary information.

#### **DISCLOSURE OF INTERESTED PARTIES**

Texas Legislature passed HB 1295 that now requires a government entity receive a Disclosure of Interested Parties (Form 1295) before entering into a contract with a vendor that requires action by the City Council. Form 1295 was created by the Texas Ethics Commission per the direction of the Texas Legislature. The form must be completed electronically on the Texas Ethics Commission website, <https://www.ethics.state.tx.us>. Once you have electronically completed the form, you must print the form, sign & notarize the form, then deliver the form to the

City of Lucas along with the executed contract. This will apply to contracts that will require Council approval, in most situations will be \$50,000 or greater.

#### **1.8 ADDENDUMS/AMENDMENTS**

Any interpretations, corrections and/or changes to a bid/proposal solicitation or extensions to the opening date will be made by addenda to the respective document when necessary. An addendum will be published and distributed by email to all that are known to have received a copy of the bid/proposal and related specifications. However, it shall be the sole responsibility of the bidder/proposer to verify issuance/non-issuance of addenda and to check all avenues of document availability prior to opening date and time to ensure bidder's receipt of any addenda issued. No addenda will be issued 3 days prior to bid opening. The last day for questions will be on **Tuesday, July 14<sup>th</sup>, 2026 at 2:00 PM**. The last day for addenda will be on **Tuesday, July 14<sup>th</sup>, 2026 at 5:00 PM**.

Any addenda issued within three working days of the bid opening will automatically delay the bid opening by one week. Bidders that attended the pre-bid meeting will be notified of the new bid opening time and date as determined by the City of Lucas Purchasing. The new bid date will also be posted on the city website.

The bidder is required to acknowledge receipt of any amendments by submitting a signed copy of each amendment issued. Signed copies must be submitted as part of the signed bid/proposal submittal.

#### **1.9 BID SUBMITTALS**

Bids/Proposals shall be submitted on the forms provided to insure complete uniformity of wording of all bids. All lump sum and unit prices must be stated in both script and figures. Bids may be rejected if they show any omissions, alterations in wording, conditional clauses, or irregularities of any kind.

*If an emergency or unanticipated event interrupts normal City processes so as to cause postponement of the scheduled bid opening, the time specified for receipt of bids will be deemed to be extended to the same time of day specified in the solicitation on the first work day on which normal City processes resume or to such other date and time as may be provided on the city website.*

#### **1.10 BIDDING ALTERNATES**

Alternatives to manufacturer-specified equipment or materials must be pre-approved in writing prior to bid opening.

#### **1.11 ACCEPTANCE**

Any offer received shall be considered an offer, which may be accepted by the City of Lucas based on initial submission without discussions or negotiations. By submitting an offer in response to this solicitation the bidder/proposer agrees that any offer it submits may be accepted by the City of Lucas at any time within 90 days from the close date.

The City of Lucas reserves the right to reject any or all offers and to waive informalities and minor irregularities in offers received, and/or to accept any portion of the offer if deemed in the best interest of the City of Lucas. Failure of the bidder/proposer to provide in its offer any information requested in the bid may result in rejection for non-responsiveness.

#### **1.12 REQUIRED FORMS TO BE RETURNED WITH BID SUBMITTAL**

- a. Certificate of Insurance
- b. Affidavit of No Prohibited Interest
- c. Bidders Qualification Statement with three references
- d. Supplemental Information
- e. Conflict of Interest Questionnaire
- f. Schedule of Subcontractors
- g. Workforce Composition
- h. Bid Schedule
- i. Bid Endorsement Page

- j. Standard Form of Agreement
- k. Bid Bond for 5% of total project due with bid submittal

**1.13 COMMENCEMENT OF WORK**

The Contractor agrees to commence work within (10) days after the date of written Notice to Proceed.

**1.14 REQUIRED BONDS**

The following bonds are required prior to contract execution OR project acceptance:

- Bid Bond – due with bid submittal
- Payment Bond – due prior to contract execution
- Performance Bond – due prior to contract execution
- Maintenance Bond to be executed at final acceptance for two (2) years and 100% of project total

**1.15 AWARD**

The City of Lucas intends to make an award using the evaluation criteria and other factors as indicated in this bid/proposal. The award shall be based on the lowest responsible and best-qualified bidder whose evaluation by the City of Lucas indicates to be in the best interest of the City and taxpayers.

Bid will be awarded on the basis of "best value". The award to the successful bidder will be determined by best value to the City of Lucas as allowed by Chapter 252 of the Local Government Code. The following criteria will be considered when selecting the successful bidder:

- the purchase price
- the reputation of the bidder and the bidder's services;
- the quality of the bidder's service;
- the extent to which the bidder's services meet the City's needs;
- the bidder's past business relationship with the City;
- the impact on the ability of the City to comply with laws and rules relating to contracting with historically underutilized businesses and non-profit organizations employing persons with disabilities;
- the total long-term cost to the City to acquire the bidder's goods or services; and
- any relevant criteria specifically listed in the request for bids or proposals.

**1.15.1 Factors for consideration in the evaluation process:**

**Invitation for Bid (Contract for Goods and Services)**

For projects with a requirement of CALENDAR DAYS TO COMPLETE PROJECT and/or TOTAL BID AMOUNT, the city may use the following schedule as the monetary value of a calendar day:

<b>Amount of Contract (\$)</b>	<b>Value of a Calendar Day (\$)</b>
Less than 25,000	100 per day
25,000 to 99,999.99	160 per day
100,000 to 999,999.99	240 per day
1,000,000 to 1,999,999.99	500 per day
2,000,000 to 2,999,999.99	1,000 per day
3,000,000 to 3,999,999.99	1,500 per day

4,000,000 to 4,999,999.99	2,000 per day
5,000,000 to 5,999,999.99	2,500 per day
6,000,000 to 6,999,999.99	3,000 per day
7,000,000 to 7,999,999.99	3,500 per day
8,000,000 to 8,999,999.99	4,000 per day
9,000,000 to 9,999,999.99	4,500 per day
10,000,000 to 10,999,999.99	5,000 per day
11,000,000 to 11,999,999.99	5,500 per day
More than 12,000,000.00	6,000 per day

Bidders should be aware that the evaluation for the award may consider the number of days bid. The value of the day will be determined by the lowest days bid and the corresponding value of the contract. The difference in the number of days will be multiplied by the calendar day value and added to each bidder’s base bid. This is also sometimes referred to as ‘A+B’ bidding.

**1.16 LIQUIDATED DAMAGES**

Bidders should be aware that the City of Lucas expects timely completion of the contract within the timeframe indicated by the bidder in their bid. Consequently, bidders should be aware that the following schedule may be applied by the City as liquidated damages for each day the project is delayed in completion:

<b>Amount of Contract (\$)</b>	<b>Value of a Calendar Day (\$)</b>
More than 12,000,000.00	2,000 per day

*Note: The sum of money thus deducted for such delay, failure, or noncompletion is not to be considered as a penalty, but shall be deemed, taken and treated as reasonable liquidated damages, per day that the contractor shall be in default after the time stipulated in the contract for completing the work.*

**1.17 RETAINAGE**

As security for the faithful completion of the work by the contractor, the owner shall retain ten percent (10%) of the total dollar amount of work done on all contracts less than \$400,000; five percent (5%) of the total dollar amount of work done on all contracts of \$400,000 or more. Retainage will be held from each progress payment/invoice through final project completion/closeout.

**1.18 BID TABULATIONS**

Bid tabulations can be accessed in the City of Lucas Website: <https://www.lucastexas.us/bid-postings>.

**1.19 CONTRACT ADMINISTRATION**

The Lucas City Engineering together with the Finance Director shall be responsible for administration of the contract for compliance with the interpretation of scope, schedule, billings, requirements, and budget.

## 1.20 SUBSTANTIVE PROPOSALS

The respondent shall certify (a) that his bid submittal is genuine and is not made in the interest of, or on behalf of, any undisclosed person, firm, or corporation; (b) that he/she has not directly or indirectly induced or solicited any other respondent to put in a false or sham bid; (c) that he/she has not solicited or induced any other person, firm, or corporation from proposing; and (d) that he/she has not sought by collusion to obtain for himself any advantage over any other respondents or over the City of Lucas.

Bidder shall sign and return a copy of the Standard Form of Agreement.

Bidders must submit a Cashier's or Certified Check, issued by a bank satisfactory to the City of Lucas, or a Bid Bond issued by a bonding company satisfactory to the City of Lucas, payable without recourse to the order of the City of Lucas in an amount not less than five percent (5%) of the largest possible bid submitted as a guaranty that Bidder will enter into a contract and execute Bond and Guaranty. Bids without required check or bid bond will be considered non-responsive.

Minimum standard for responsible prospective bidders are as follows:

- Have adequate financial resources, or the ability to obtain such resources
- Be able to comply with the required or proposed schedules and project requirements
- Competitive pricing
- Have a satisfactory record of performance for contracts of similar scope (complete attached reference sheet)
- Have a satisfactory record of integrity and ethics
- Completeness and thoroughness of bid submittal

The City of Lucas may make such investigations as it deems necessary to determine the ability of the bidder to provide satisfactory performance in accordance with bid requirements, and the respondent shall furnish to the City all such information and data for this purpose.

## 1.21 DEFINITIONS

Bidder refers to submitter.

Vendor refers to Successful Bidder or Contractor.

Submittal refers to those documents required to be submitted to the City of Lucas, by a bidder.

## 1.22 INQUIRIES

Questions resulting in changes to this solicitation will be provided in the form of an amendment to the solicitation. Questions about this bid shall be in writing and directed to the procurement website, Civcast.

**1.23 SCHEDULE OF EVENTS**

The upcoming schedule of events is tentative scheduled as follows:

Public Advertisements	Monday, May 11, 2026
	Monday, May 18, 2026
	Monday, May 25, 2026

Pre-Bid Conference	May 26, 2026	at 10:00 AM
--------------------	--------------	-------------

Open Bids	July 21, 2026	at 2:05 PM
-----------	---------------	------------

Council Awards Contract (Anticipated)	Thursday, August 6, 2026
---------------------------------------	--------------------------

Notice of Award (Anticipated)	Friday, August 7, 2026
-------------------------------	------------------------

Notice to Proceed (Anticipated)	Monday, August 10, 2026
------------------------------------	-------------------------

Finish Construction	As determined by Contractor's proposal. Calendar Days following official written Notice to Proceed.
---------------------	---

# Special Specification 7122

## Sanitary Sewer



### 1. DESCRIPTION

#### 1.1. Scope of Work

Provide and install complete sanitary sewer construction and adjustments in conformity with the details shown on the plans, as described herein, in compliance with the Department's Utility Accommodation Policy (UAP)(Title 43, T.A.C., Sections 21.31-21.55) or as directed.

Reference specifications of the American Society for Testing and Materials (ASTM), American Water Works Association (AWWA) and American National Standards Institute (ANSI) will mean the latest standard in effect on the date of the proposal.

#### 1.2. Definitions.

Sanitary Sewer Main. Sanitary Sewer Main is defined as that portion of the sanitary sewer system which collects the wastewater from the service laterals, including stub outs from the nearest manhole, to the point of final destination.

Service Lateral. Service Lateral is defined as that portion of the sanitary sewer system beginning at a customer property line or other establishment property line which is the point of origin of the wastewater being carried by the system to the sanitary sewer main, including the connection into the sanitary sewer main system.

Point Repair. Point Repair is defines as the repair of a small length of pipe section of an existing sewer line which has deteriorated due to settlement or corrosion, or is falling, missing, crushed or broken, or has offset joints. Point repairs are to be completed before rehabilitation by trenchless methods between two adjacent manholes is initiated.

Rehabilitation. Rehabilitation is defined as the rehabilitation of existing sanitary sewer mains by an approved trenchless method including Cured-In-Place-Pipe (CIPP) method or by sliplining with Centrifugally Cast Fiberglass Pipe (ASTM D-3262) or by sliplining with hollow Core I-Beam construction Closed Profile PVC Pipe (ASTM D-F794).

Cured-In-Place-Pipe. This method consists of inverting a resin-impregnated flexible sewn felt tube into the original conduit by use of hydrostatic head. The resin is cured by circulating hot water within the tube. The Cured-In-Place-Pipe (CIPP) will be continuous and tight fitting. The work shall be completed with TxDot schedule. Contractors may, when appropriate, elect to use any material that is considered to be equal (i.e. A product that has structural physical properties that are equal or greater than those of the specified products), however, submittal to the design Engineer is required no later than 10 days prior to bid opening.

Television Inspection. Television Inspection is defined as televising and videotaping of sewer lines utilizing a color closed circuit television inspection unit to determine the condition of the lines.

Television Inspection is part of the acceptance requirements for new sewer lines. All new sewer mains will not carry flow until the Engineer and/or Inspector approve and accept the mains for service.

Cleaning Manholes and Mains. Cleaning Manholes and Mains is defined as cleaning of existing sanitary sewer manholes and mains to facilitate the TV inspection and rehabilitation of the sanitary sewer mains.

The designated sanitary sewer manhole sections and the manholes themselves shall be cleaned using mechanical, hydraulically propelled or high velocity sewer cleaning equipment. Debris generated by the cleaning process shall be removed from the manhole, transported and disposed of.

By-Pass Pumping. By-Pass Pumping is defined as by-pass pumping of sewage flow for the purpose of preventing interference with the rehabilitation of the sanitary sewer manholes and mains as well as providing reliable sewer service to the building being served.

Manhole Rehabilitation. Manhole Rehabilitation is defined as substrate rehabilitation for the purpose of eliminating infiltration, providing corrosion protection, repair of voids, and restoration of the structural integrity of the manhole by applying a monolithic fiber-reinforced structural and structurally enhanced cementitious liner to the wall and bench surfaces of brick, concrete, or any other masonry construction material.

Pipe Bursting or Crushing Replacement Process. The pipe bursting or crushing process is defined as the reconstruction of existing sanitary sewers by the simultaneous insertion (breaking and expanding the old pipe) of liner pipe within the bore of the existing pipe. The pipe bursting or crushing process involves the rehabilitation of deteriorated gravity sewer pipe by installing new pipe material within the enlarged bore created by the use of using s static, hydraulic, or pneumatic hammer "moling" device, suitably sized to break the existing pipe or by using a modified boring "knife" with a flared plug that crushes the existing sewer pipe. Forward progress of the "mole" or the "knife" may be aided by hydraulic equipment or other apparatus. Replacement pipe is either pulled or pushed into the bore. Sewer services are reconnected to the new pipe through small excavations from the surface. Sewage flows from the upstream line and from the services are pumped as required to prevent overflows and provide continual service. All excavations required for reconnecting and pumping service flows, entry pits, exit pits, obstruction removal, point repairs, among others, are to be kept to a minimum and all damage to surface and underground features, facilities, utilities and improvements are to be repaired.

Sliplining. Sliplining is accomplished by pulling or pushing liner pipe into existing sewers by use of mechanical or hydraulic equipment. Once in place, liner pipe is allowed time to normalize and is then cut to fit between the manholes. Manhole inverts and benches are re-worked and re-shaped. Existing sewers remain in operation during sliplining process, with sewage flow diverted around operations in progress.

---

## 2. MATERIALS

All materials furnished for this project will be new. A manufacturer's certificate of compliance will be acceptable for quality control.

### 2.1. Sanitary Sewer Pipe

Materials for sanitary sewer pipe may be either rigid or flexible unless a specific type pipe is called for on the plans. Install materials as specified by the manufacturer.

#### 2.1.1. Rigid Pipe

Ductile iron pipe shall, for the purpose of this specification, be known as rigid pipe. Ductile iron pipe and fittings are for use on force mains and shall not be allowed for use in gravity applications. All ductile iron pipe shall be provided with corrosion resistant linings

#### 2.1.2. Flexible Pipe

Pipe consisting of materials other than those listed above.

Any flexible conduit having a deflection of the inside diameter greater than 5 percent after 30 days of installation as determined by a mandrel test, will not be accepted.

Unless directed otherwise by the Engineer and/or Inspector, a "GO, NO-GO" Deflection Testing Mandrel built in accordance with the detail drawing, as shown in the plans, and 30 TAC § 217, shall be furnished at the Contractor's expense and shall be used in testing pipe deflection for acceptance. Refer to "Air and Deflection testing," section of this specification for more information about mandrel deflection testing.

Pipe stiffness is to be in accordance with ASTM 3034 SDR 26 [115 psi] or ASTM 2241 SDR 26 [160 psi].

At waterline crossings and where water and sewer mains are parallel and separation distance cannot be achieved as per 30 TAC§ 217.53, use extra stiff pipe SDR 26 PVC (ASTM D2241-09) with a pressure rating of at least 150 psi. This shall include all lateral piping as well.

All sanitary sewer piping shall pass the low pressure test, as described in 30 TAC § 217.57.

When the trench width is greater than the outside diameter of the pipe plus 2-ft. the pipe will be covered with Class B concrete, in accordance with Item 421, or as shown on the plans.

2.1.3. Concrete Pipe

Concrete pipe shall not be used.

2.1.4. Asbestos-Cement (AC) Pipe

AC pipe shall not be used. Confer with the City of Converse Engineer for existing AC pipe and material handling.

2.1.5. Fiberglass Reinforced Sewer Pipe, Non-Pressure Type.

Fiberglass reinforced sewer pipe, non-pressure type, shall be a factory-formed conduit of polyester resin, continuous roving fiberglass and silica sand built up in laminates and shall conform to the requirements of ASTM D3262-11, including the appendix and subsequent specifications, and in accordance with City of Converse's material specifications. Depths shall comply with requirement of ASTM D3681-12.

Coupling Joints: Joints for pipe and fittings shall be confined compression rubber gasket bell and spigot type joints conforming to the material and performance requirements of ASTM D4161-01. Depths shall comply with requirement of ASTM D3681-12.

Fittings: Flanges, elbows, reducers, tees, wyes, laterals, and other fittings shall be capable of withstanding all operating conditions when installed. They may be contact molded or manufactured from mitered sections of pipe joined by glass-fiber reinforced overlays. For pipe diameters 15 inches or larger, lateral openings 6 inch or greater in size shall be made using PVC sewer saddles conforming to ASTM D2661-11 or service connections conforming to ASTM D3034-08, and approved by the Engineer.

Minimum pipe stiffness shall not be less than 115 psi for direct bury applications.

2.1.6. PMS PVC Pipe.

Polyvinyl Chloride (PVC) pipe will be made from class 12454-B materials as prescribed in ASTM D-1784. For pipes 4" to 15" in diameter PMS pipe, fittings and joints shall conform to ASTM D-3034 and elastomeric gasket joints meeting D-3212, and ASTM D-2241 and ASTM D-3139 where applicable, with the exception that solvent cement joints shall not be used. All pipe that is 18" to 27" in diameter shall meet requirements of ASTM F-679.

Water Main Crossings

Gravity or force main sewers constructed in the vicinity of water mains will comply with the requirements of the "Criteria for Domestic Wastewater Systems," 30 TAC 217.53, as adopted by The Texas Commission on Environmental Quality, latest revision.

Mechanical or compression joints, concrete jointing collars, or non-reinforced rubber adaptors shall be used only as approved by the Owner.

2.1.7. Pressure Pipe/Force Mains

Pipe shall be made from Class 12454-B, as defined in ASTM D1784-11. All pipe, fittings, and joints shall meet or exceed the requirements of ASTM D2241-09, with the exception that solvent cement joints shall not be used. The pressure rating, size, and pressure class shall be as shown in the contract documents. Pipe shall have an integral bell and gasket seal with the locked-in type gasket reinforced with a steel band or other rigid material conforming to ASTM F477-10. The joint shall comply with the requirements of ASTM D3139-98(2011). All required joint restraint shall be approved by the Engineer and/or Inspector prior to the work being accepted. Pressure pipe/Force mains are required to have modified grade 5 material used as bedding. Pipes also shall be hydrostatically tested at a minimum of 100 psi after their construction to ensure proper construction.

2.1.8. Mechanical or compression joints

Mechanical or compression joints, concrete jointing collars, or non-reinforced rubber adaptors shall not be used unless as approved by the Engineer and/or Inspector.

2.1.9. Ductile Iron Pipe and Fittings

Ductile iron pipe shall be centrifugally cast of 60-42-10 iron and shall conform to the requirements of the latest revision of ANSI Standard A21.51/American Water Works Association (AWWA) C151-09. Ductile iron pipe may be "thickness designed" in accordance with requirements of the latest revision of ANSI Standard A21.50/AWWA C150-08. Thickness design shall be based on standard laying conditions 4 or 5 in accordance with conditions at the site. Fittings for ductile iron pipe shall have not less than the thickness, class, or pressure rating specified for ductile iron pipe. Fittings shall be furnished with all necessary glands, gaskets, bolts, etc. as may be required to complete the joints.

Rubber gasket joints for mechanical joints or push on type joints shall conform to the requirements of ANSI Standard A21/AWWA C111-12.

All ductile iron pipe and fittings shall be cement mortar-lined or polyethylene-lined. The cement mortar lining shall be in accordance with ANSI A21.4/AWWA C104-08.

The polyethylene lining material for pipe and fitting shall be virgin polyethylene complying with ANSI/ASTM D1248-12, compounded with inert filler and with sufficient carbon black to resist ultraviolet rays during storage of the pipe and fittings. The polyethylene shall be bonded to the interior of the pipe or fitting by heat. Polyethylene lining in pipe and in fittings shall be 40 mils nominal thickness. Minimum lining thickness shall be 30 mils.

2.1.10. Concrete Steel Cylinder Pipe

Concrete Steel Cylinder Pipe shall not be used.

2.1.11. Pipe Testing.

All sanitary sewer pipe and fittings produced within the jurisdiction of the City of Converse shall be tested by City of Converse-approved laboratory method at the source of supply. All shipments of pipe not so tested shall be accompanied by a certificate of compliance to these specifications prepared by an independent testing laboratory and signed by a Texas licensed professional engineer.

## 2.1.12. Ductile Iron Pipe with Polybond Lining

The lining will be a composite lining utilizing a primer coating containing fusion bonded epoxy (FBE) and a surface coating containing fusion bonded polyethylene (FBP). The lining will be Polybond PLUS as manufactured by the American Cast Iron Pipe Company (Birmingham, AL) or an approved equal meeting the requirements of this specification. All lining application must be performed by the pipe manufacturer at the pipe manufacturer's facility. Linings applied by individuals other than the pipe manufacturer are unacceptable and will be rejected. Type and brand of lining shall be marked on each pipe or fitting.

## Primer

The primer is to contain fusion bonded epoxy (FBE), which is applied in sufficient quantity to achieve a normal thickness of 5 mils for the pipe or fitting. The FBE material used in the primer formulation should be capable of meeting the following requirements.

TEST PARAMETER	ASTM TEST METHOD	TYPICAL VALUE
Tensile Strength	D-2370	9,300 psi
Compressive Strength	D-695	11,600 psi
Ultimate Elongation	D-2370	6.9 percent
Impact (1/8"x3"x3" panel) 5/8" diameter tup	G-14	160 in.-lbs

Surface layer: The surface layer will be comprised of medium density modified fusion bonded polyethylene (FBP) meeting the requirements of ANSI/ASTM D1248 and compounded with an inert filler. The FBP will be formulated to be ultra-violet (UV) resistant for a minimum of three (3) years exposure. The color of the FBP is to have a light reflective value (LRV) of at least 40 percent to aid in the in-situ inspection of the pipeline with video equipment.

The fusion bonded polyethylene used in the surface coating material will be capable of meeting the following requirements:

TEST PARAMETER	ASTM TEST METHOD	TYPICAL VALUE
Tensile Strength	D-638	1,650 psi
Ultimate Elongation	D-638	300 percent
Taber Abrasion Resistance	D-4060	25.0 mg wt. loss/1,000 cycles @ 1,000 gram load
Notched Izod Impact @ 23	D-256	8.0 ft.-lbs/in.

		(No break)
@ 60 C		6.1 ft.-lbs/in.
		(No break)
Brittleness Temperature	D-746	-76 C

**Thickness Requirements:** Total thickness for the fusion bonded epoxy/fusion bonded polyethylene lining will be 60 mils nominal with a 50 mil minimum in the barrel of the pipe.

**Lining Coverage:** The fusion bonded epoxy/fusion bonded polyethylene lining will cover the interior surface of the pipe and fittings from the interior of the spigot end to a point sufficiently forward in the bell socket such that the Fastite gasket, in the assembled joint, seals over the end of the lining.

**Joint Surface Coating:** The joint surface coatings are to be comprised of a two component epoxy. The use of joint surface coatings containing coal tar is prohibited. Total thickness for the joint coating is to be 8 mils nominal.

The joint surface coating is to cover the spigot end across the end of the spigot bevel and extending over the outer surface of the spigot including the gasket sealing area. The joint surface coating is to also cover the socket from the face of the bell, through the gasket sealing area overlapping onto the edge of the FBE/FBP lining.

For each production lot, the lining is to be tested over 100 percent of the pipe barrel surface with a high voltage spark tester as recommended by ASTM Designation G-62 Method B of the latest version. The minimum test voltage is to be as determined by Method B, as described in the ASTM Designation Section 11.2.3, which is the recommended voltage for all linings with possible areas thicker than 41 mils:

$$V = 1250 \times T^{1/2} \quad \text{where } V = \text{voltage and}$$

$$"T" = \text{thickness of lining in mils.}$$

$$\text{Example: } V = 1250 \times 60^{1/2} \text{ Minimum Voltage} = 9,683 \text{ volts}$$

If holidays are found in the lining by the above test at the manufacturing plant, the holiday is to be repaired per the lining manufacturer's recommendation.

The holiday detector is to be a commercially available detector available from holiday detection equipment manufacturers such as SPY, TINKER and RASOR, and ZORELCO.

**Voltage Confirmation Test.** To confirm that the above voltage is sufficient to detect holidays, the following voltage confirmation test should be performed for each shift or change in detector operator. The holiday detector should be set to the calculated minimum voltage shown above. A known holiday should be made in the lining of a randomly selected pipe using a small sharp pin. The operator should demonstrate that the holiday can be consistently and satisfactorily located at this voltage setting and detector wand speed. If the holiday is not detected at the calculated voltage, then the voltage should be slowly increased until the known holiday is consistently detected by the operator. This voltage should then become the minimum voltage at which all pipe linings are to be tested.

**Testing Voltage Meter.** The detector's voltage (and voltage meter) is to be tested once each day by a separate voltmeter and the results certified by the pipe manufacturer, to confirm the accuracy of the detector's voltage meter.

### 2.1.13. High Density Polyethylene (HDPE) Pipe and Fittings

All HDPE will have a minimum pressure rating of 200 psi and a dimension ration of 9 (DR 9).

Where standard ductile iron mechanical joint fittings are coupled to plain-end (square-cut) HDPE pipe, mechanical joint adapters must be used. Use Driscopipe Mechanical Joint Adapter (DIPS) Kit or approved equal.

**Ductile Iron Bends and Fittings for HDPE Pipe.** All bends and fittings will be furnished with the type of joint and end combinations specified. Mechanical joint fittings will be furnished complete with glands, gaskets and bolts. Flanged joint fittings will be furnished complete with gaskets and bolts. All bolts, glands and gaskets will be in accordance with AWWA Standard Specification C111.

All fittings will be furnished with standard outside coatings consisting of coal tar or asphalt base bituminous materials. Fittings will be cement mortar lined and sealed in conformity with AWWA Standard Specification C104.

**Pipe Joint Restraint System for HDPE Pipe.** Restraint devices will be used where ductile iron mechanical joint bell fittings are coupled to plain-end (square-cut) HDPE pipe, to prevent movement of pipe connections. The restraint system will have a minimum pressure rating of 250 psi. The restrainer must not be directionally sensitive.

Underwriter Laboratories and Factory Mutual certifications will be required on the restraint system. Each restraint device will be packaged individually and include installation instructions.

The pipe will be restrained by a split retainer band that will be cast ductile iron, meeting or exceeding ASTM A536 Grade 65-45-12. The inside face or contact surface of the band will be of sufficient width to incorporate machined non-directionally sensitive serrations to grip the outside circumference of the pipe. The serrations will provide full (360°) contact and maintain pipe roundness and avoid any points of localized stress. The split band casting will be designed to bottom-out before clamping forces (110 ft.-lb. minimum torque) can over-stress the pipe, but will provide full non-directionally sensitive restraint at the rated pressure.

Bolts and nuts used to attach the split retainer ring will comply with ANSI B 18.2/18.2.2, SAE Grade 5. Tee bolts, nuts and restraining rods will be fabricated from high strength, low-alloy steel in accordance with AWWA C111.

Restraint devices will be Uni-Flange Block Buster 1300C or approved equal.

**Water Main Crossing.** Where HDPE force main sewers are constructed in the vicinity of potable water mains, the requirements of the Texas Commission on Environmental Quality (30 TAC 217.53) will be met.

### 2.1.14. Steel Casing Pipe.

The component materials, manufacture and testing of all steel pipe will conform to AWWA Standard C-200 for "Steel Water Pipe 6-in. and Larger". The specified pipe size will be the actual inside diameter of the pipe, special or fitting in inches. The diameter and wall thickness of all steel pipe will conform to those shown on the plans.

Pipe will be either Grade A or Grade B, conforming to ASTM Designation A-53.

Pipe ends will be beveled and suitable for field butt welding except as otherwise specified.

Pipe will receive a protective coating conforming to AWWA Standard C-203, "Coal-Tar Protective Coatings and Linings for Steel Pipelines – Enamel and Tape Hot Applied".

Pipe length will be nominal 40 ft. lengths except for specials or as otherwise specified on the plans. Standard and specials will be within 1/16-in. (plus or minus) of the specified or theoretical lengths.

#### 2.1.15. Stainless Steel Casing Spacer/Insulators

This section covers casing spacers for use in water supply service. Casing spacers are used to facilitate installing a water pipe inside a casing pipe or tunnel. Casing spacers shall consist of two or more segments of circular steel that bolt together forming a shell around the carrier pipe(s). Casing spacers should protect the carrier pipe and any protective coating or wrapping from damage during the installation, and properly support and electrically isolate the carrier pipe(s) within the casing or tunnel. On occasion multiple carrier pipes may be installed in one casing or tunnel.

##### 2.1.15.1. General Requirements

The City of Converse reserves the right to limit the purchase of casing spacers from the manufacturers and to the models specified as shown in paragraph 4, providing such casing spacers conform to the provisions contained herein.

Casing spacers shall be eight inches (8") long for carrier pipes up to 16- inch diameters and twelve inches (12") long for larger carrier pipe sizes. Manufacturer's approval in writing shall be required for installations exceeding 300 ft. in length, carrier pipes in excess of 48- inch diameter or multiple carrier pipes in one casing or tunnel.

Casing spacers shall have a minimum 14-gauge steel band and 10 gauge steel riser when required. The band, risers and connecting studs shall be welded and cleaned at the factory before the application of a fluidized bed fusion bonded PVC coating. Stainless steel (type 304) casing spacer is an acceptable alternative.

The fluidized bed fusion bonded PVC coating shall be between 10-16 mils thickness. The PVC coating shall provide good resistance to acids and alkalize and excellent resistance under ASTM B117 salt spray tests. The coating shall have a minimum 1380volts/mil per ASTM D149-61 short time 0.010" test and a Durometer-shore A@ (10 sec) of 80 per ASTM D1706-61T. Epoxy coatings are not an acceptable alternative.

The spacers shall have a flexible PVC liner of 0.09-inch thickness with Durometer "A" 85-90 hardness and a minimum 58,000- volt dielectric strength (60,000-volt minimum Surge Test.) Moisture absorption shall not exceed 1%.

The runners shall be of high pressure molded glass reinforced polyester with a minimum compressive strength of 18,000 psi per ASTM D695, flexural strength of 25, 300 psi per ASTM D790, tensile strength of 17,600 psi per ASTM D638 and Rockwell hardness (M) of 90 per ASTM D785. The riser shall be designed and fabricated to place the runner (skid) in full contact with the inside surface of the casing pipe. This evenly distributes the load force to all support members. The ends of all runners shall be shaped to resist hanging or sticking inside casing during installation of the carrier pipe. Polyethylene runners are not acceptable.

Runners shall be a minimum of 1.0 inch in width and a minimum of 7 inches long for carrier pipes up to 16", and a minimum of 2.0 inches in width and 11 inches long for larger carrier pipes. Bolts on runners are not acceptable. The runners shall be attached to the band or riser by 3/8 the wearing surface on the runner. The recess shall be filled with a corrosion inhibiting filler. There shall be four runners per casing spacer for carrier pipes up to 12" diameter, six runners for 14" through 36" and eight or more runners for carrier pipes over 36" diameter. Number of bottom runners shall be multiples of two. Number of top runners shall be multiples of two.

The band section shall be bolted together with 5/16" cadmium-plated studs, nuts and washers. There shall be six sets per 8" long casing spacer and eight sets per 12" long spacer. Stainless steel casing spacers shall be furnished with stainless steel studs, nuts and washers.

Casing spacers shall have ample riser height to limit vertical movement of the carrier pipe in the casing. A minimum of 1" to 2" clearance shall be provided between the top runner and the ID of the casing or tunnel.

Continuous operating temperatures for the PVC Coated Casing Spacers should not exceed 150°F. Stainless steel casing shall be used in applications where continuous operating temperatures exceed 150°F.

Unless noted otherwise, casing spacers shall be required on all carrier pipes installed in casing or tunnel applications.

#### 2.1.15.2. Quality Assurance

All casing spacers are to be manufactured in accordance to NACE International Recommend Practice RP 0286-97 (Isolation Spacers.) Each casing spacer shall be manufactured in the USA at a facility that has a Registered ISO 9002 Quality Management System or be in the process of achieving this certification by March 2005. Non-compliance to this registered commercial quality system requirement by March 2005 will result in removal of the manufacturer's product from paragraph 4 approved manufacturers.

If on receipt of casing spacers they are found to be non-compliant, the manufacturer shall replace the defective casing spacer with a casing spacer that meets the City of Converse's specifications, at no charge to the City of Converse.

If the City of Converse audits, product inspection and performance data review in accordance to these specifications determine excessive casing spacer Noncompliance, the manufacturer will be subject to removal by the Products Standard Committee. Copy of the current ISO 9002 registration (or written documentation of being "in the process of achieving ISO registration," prior to March 2005) shall be provided with material submittal.

#### 2.1.16. Water Main Crossings

Gravity or force main sewers constructed in the vicinity of water mains will comply with the requirements of the "Criteria for Domestic Wastewater Systems," 30 TAC 217.53, as adopted by The Texas Commission on Environmental Quality, latest revision.

#### 2.2. Manholes

Material for manholes will conform to the requirements of Item 465, "Manholes and Inlets", as described herein and as shown on the plans.

All material and construction work shall be in accordance with current Texas Commission on Environmental Quality (TCEQ) rules to include: Design Criteria for Sewage Systems (30 TCEQ § 217). All constructed manholes shall be watertight. Manhole covers may be either watertight or water resistant, depending on their specific location. Every manhole cover located in an identified 100-year floodplain, or in the Edwards Aquifer Recharge Zone, shall be watertight. Sewer manhole ring and cover castings shall meet the current requirements of AASHTO Designation M306-10.

Unless otherwise shown in the contract documents or approved by the Engineer and/or Inspector, standard sanitary sewer manholes shall be constructed with influent and effluent piping less than or equal to 24 inches in diameter with precast reinforced concrete manhole sections. A standard sanitary sewer manhole shall be a single entrance cylindrical structure, having a minimum internal diameter of 4 feet between the cone and base sections. The base of the structure shall include the load bearing portion beneath and exterior of the structure, invert channels and the fill or bench portions adjacent to the lower sewer pipes within the structure. The maximum vertical height of the diameter adjustment section or cone shall be 36 inches. Adjustment or throat rings may be used for final elevation adjustment of the manhole ring and cover. Concrete encasement of the manhole's ring shall be as shown in the plans. Specifically, they shall attach the ring and cover to the diameter adjustment section or cone. Manholes which differ from the above description shall be identified as "Manhole Structures"

An internal drop manhole shall be required, when sewer lines enter a manhole more than 24 inches above the manhole invert, while an external drop manhole shall be provided for a sewer entering a manhole more than 30 inches above the invert. Both conditions will require prior approval by the Engineer and/or Inspector.

#### 2.2.1.1. Manhole Structures

Cast in place concrete structures or pre-cast concrete structures, as detailed on the plans, will be installed where any pipe intercepted is larger than 24-in. in diameter.

#### 2.2.1.2. Precast Reinforced Concrete Manhole Sections

Precast reinforced concrete manhole sections shall conform to the requirements of ASTM Designation C478-12a.

#### 2.2.1.3. Manhole Ring and Cover

The standard manhole ring and cover shall be ductile iron and manufactured to the dimensions shown on the plans. The ring and cover shall be hinged. Lifting slots cast into the covers shall be provided for lifting purposes. A water-resistant (cam lock) ring and cover shall be used in areas of minimal infiltration potential to allow venting. A watertight (bolt down) ring and cover must be used in areas of high infiltration potential, such as in the Edward's Aquifer Recharge Zone, an identified 100-year floodplain, or as otherwise directed by the Engineer and/or Inspector.

The nominal cover diameter shall be 32 inches, with a 30 inch clear opening, as required by TCEQ. Rings shall have a minimum of four 1 inch holes/slots for anchoring purposes. Rings shall be a minimum of 4-1/2 inches in height, or as otherwise accepted by the Engineer and/or Inspector. Slots for embedment/lightening are not allowed in ring flanges.

**Water-resistant Rings and Covers:** Rings and covers shall have two hinges for added stability. The hinge shall have a drain to allow for proper debris and foreign object removal. Prior to acceptance of the work, a stainless steel keyed "cam" lock shall be provided by the Contractor to the Inspector. When the key is inserted in the cam, it shall remain in the lid while the cam is in the open (unlocked) position. When in the closed (locked) position, the key can be removed. When not in use, the cam lock key hole shall be covered with a plastic plug to prevent infiltration of debris. The cover shall positively lock at 90° to prevent accidental closure and open fully to 120°. The cover shall also include a single multi-tool lifting slot adjacent to the edge of the cover to facilitate opening/lifting/prying once it is unlocked. Covers shall be provided with a continuous vulcanized (one piece) EPDM gasket with a shore durometer of 70 ±5 permanently attached to the cover.

**Watertight Rings and Covers:** Rings and covers shall be the same as above for water-resistant version, except the covers shall be bolted to the ring instead of secured with the cam lock mechanism. No vent hole(s) shall be provided. A minimum of four 1/2 inch diameter, stainless steel, hex head bolts shall be provided for each cover. The 4 bolt holes in the covers shall be evenly spaced and provided with a minimum 1-1/2 inch diameter counter sink for the bolt heads. On the fastened and bolted position, the bolt heads shall not extend above the surface or the cover. Washers of a size and material as approved by the Engineer and/or Inspector shall be provided for the bolts to insure air and water tightness.

The finished ring and cover shall have the bearing surfaces machined ground and sets of rings and covers shall be marked in such a way that they can be matched for assembly in the field. All covers shall have the words "SANITARY SEWER" cast thereon.

Ring and cover shall have the approved foundry's name, part number, country of origin preceded by "Made in" (example: MADE IN USA) in compliance with the country of origin law of 1984, and production date (example: mm/dd/yy) for tracking purposes. Each casting must be marked with DI and ASTM A536 or A536 80-55-06 to verify the materials used. Castings without proper markings shall be rejected.

#### 2.2.1.4. Throat Rings

Throat rings shall be made of either HDPE or reinforced concrete and have a maximum thickness of 2 inches. The internal diameter shall match that of the ring and cover's opening. Concrete shall conform to the provisions of Concrete (Class "A"), Item No. 421 Hydraulic Cement Concrete. If concrete throat rings are to be utilized, they must be used in conjunction with a UV stabilized polyethylene liner. I/I barrier must meet the following ASTM standards: ASTM D790/1505 Density of Polyethylene Materials, ASTM D1238-10 Melt Flow index, ASTM 638-10 Tensile Strength @ Yield (50mm/mm), ASTM 790-10 Flexural Modulus, ASTM 648-07 Heat Deflection Temperature @IGEPAL, ASTM 1693-12 EsCR, 100% IGEPAL/10% IGEPAL. A minimum of two and a maximum of four throat rings may be used at each manhole installed.

#### 2.2.1.5. Coating

All manholes shall be watertight and coated with a City of Converse approved sewer coating. Prior to coating, all manholes shall be vacuum tested, and approved. For existing and rehabilitated manholes, apply a combination of both products with the cementitious coating first, followed by the epoxy coating. Kerneos SewperCoat 2000 HS regular, applied at the required one inch thick application, is the only product approved which does not require a subsequent epoxy coating. New manholes installed do not require the cementitious coating. Cementitious liner thickness shall be measured by the penetration method at locations specified by City of Converse prior to the final setting of the material. Approved materials are as follows:

Cementitious coating: With required one inch thick application:

- Permaform CR-5000;
- Strong - Seal MS-2C;
- Standard Cement Material Inc. Reliner;
- Quadex Aluminaliner;
- ConShield Biotech Armor.

Epoxy coating: With specified thickness application:

- Raven 405 Series High Build Epoxy Liner: Required thickness – 125 mils;
- Spray Wall polyurethane System: Required thickness – 125 mils;
- Carboline "Plasite 4500" System: Required thickness – 125 mils.

#### 2.3. Manhole Rehabilitation

The Contractor shall submit descriptive information including technical data sheet and ASTM test results on each product proposed indicating that the product conforms to and is suitable for its intended use per the specifications. The Contractor may, when appropriate, elect to use any materials that is considered to be equal (i.e. a product that had structural and physical properties that are equal to or greater than those of the specified product). However, submittal to the Engineer is required no later than 10 days prior to bid opening. Should the Contractor elect to use any materials other than those contained herein, they should be completely and clearly identified when making the product submittal. This will expedite the review process, in which the Engineer decides whether the products meet the Contract requirements and the specific use foreseen. The purpose of this process is to expedite review of Contractor product submittals.

Concrete shall conform to Item 420, "Concrete Structures".

Mortar shall be composed of 1 part Portland cement, 1 part masonry cement (or 1/4 part hydrated lime), and masonry sand equal to 2.5 to 3 times the sum of the volumes of the cements and lime used.

Unless otherwise specified, all grouting shall be done with non-shrinking grout.

Reinforcing steel shall conform to the requirements of Item 440, "Reinforcing Steel".

Replacement brick for ring adjustment courses shall be of first quality, sound, kiln fired, new unbroken brick.

Structural or High Sulfate resistant lining for rehabilitation shall be Raven 405 Series high build Epoxy Liner minimum 200 mils thick, Spray Wall polyurethane system minimum 250 mils thick or equal (i.e. a product that has structural and physical properties that are equal to or greater than those of the specified product).

2.4. Cleaning Manholes and Mains

2.4.1. Preparation.

The Contractor shall be required to have all materials, equipment and labor necessary to complete the cleaning of the sanitary sewer main and manholes on the job site prior to isolating the sewer manhole or main segment and beginning the cleaning process.

2.4.2. Cleaning Materials.

Use only cleaning materials recommended by manufacturer of surface to be cleaned. Use each type of cleaning material on only those surfaces recommended by the cleaning materials manufacturer. Use only materials which will not create hazards to health or property or affect treatment plant process.

2.5. Concrete

All concrete is to meet the requirements of Item 421, "Hydraulic Cement Concrete". Unless otherwise shown on the plans or required by this specification, all concrete will be Class A.

2.6. Mortar

Mortar shall be composed of 1 part Portland Cement, 2 parts sand and sufficient water to produce a workable mixture. When used to plaster manholes, it may be composed of 1 part cement to 3 parts sand. Lime up to 10% may be used. It will have a consistency such that it can be easily handled and spread.

2.7. Reinforcing Steel

Reinforcing steel and the placing thereof is to conform to the requirements of Item 440, "Reinforcing Steel", except where welded wire is called for on the plans, the material will be welded wire flat sheets meeting A.S.T.M. A-185. Welded wire rolls will not be used.

2.8. Cement Stabilized Backfill

Cement stabilized backfill is to be in accordance with Item 400, "Excavation and Backfill for Structures".

2.9. Flowable Backfill

When indicated on the plans, the trench is to be backfilled to the dimensions shown with flowable backfill. The flowable backfill with fly ash will be Mix Design Type B in accordance with Item 401, "Flowable Backfill", or an acceptable mix as approved.

2.10. Grout

When shown on the plans for various applications, the grout is to be a cement/sand/water mixture as approved. It will have a consistency such that it will flow into and completely fill all voids.

2.11. Sewer Main Television Inspection

The Contractor shall furnish all labor, materials, equipment, and incidentals to provide the televising and a NASSCO-(PACP) standard video, recorded in MPEG-1 format and written to DVD video of sewer lines and manholes utilizing a color, closed-circuit television inspection unit to determine their condition.

The Contractor shall provide a line diagram area sketch and written log for each completed segment of DVD sewer main describing the section being televised, flow and camera direction, position of service connections, description and location of failures, pipe condition, weather conditions, and other significant observations.

Television inspection shall be done one manhole section at a time. Also the flow in the section being televised shall be bypassed if the line is in service and the flow exceeds 25% of the internal pipe diameter. When the depth of flow at the upstream manhole of the manhole section being worked is above the maximum allowable for television inspection, the flow shall be reduced to allowable levels by temporarily plugging or blocking the flow or bypass pumping, as approved by Inspector.

The Contractor shall not be allowed to float the camera. There may be occasions during the televised inspection of a manhole section when the camera will be unable to pass an obstruction. At that time, and prior to proceeding, the Contractor shall contact the Inspector. If the length of sewer line cannot be televised because of obstructions, the Contractor shall clean the system as is necessary. If, in the opinion of the Inspector, the obstruction is attributed to a collapsed main or pipe deflection, televising shall be suspended, payment shall be made based on the actual televised length, and the remaining televising of the sewer line shall be continued upon successful correction of the blockage by the Contractor at his expense. No additional payment shall be made for additional setups required due to obstructions encountered during televising.

Log Formats. Each DVD will be permanently labeled with the following:

- Project Name,
- Date Televised,
- Station to Station Location and Size of Sanitary Sewer,
- Street/Easement Location,
- Name of Contractor,
- Date DVD Submitted, and
- DVD Numbers.

Videotape Quality. If the Contractor produces a DVD of poor quality that the Engineer and/or Inspector is unable to evaluate the condition of the sanitary sewer main or locate the sanitary sewer service lateral connections, the Contractor will be required to re-televising the sanitary sewer main and provide a new DVD of good quality at no additional cost.

Equipment Required For TV Inspections. The Contractor will be required to have all materials, equipment and labor necessary to complete all videotaping on job site prior to isolating the sewer manhole segment and beginning videotaping operations. A camera with rotating or panning lens capabilities is required. The television inspection equipment shall have an accurate footage counter which displays on the monitor the exact distance of the camera from the center of the starting manhole. A camera with rotating and panning lens capabilities is required. The camera height shall be centered in the conduit being televised. The speed of the camera through the conduit shall not exceed 40 feet per minute.

The television unit shall also have the capability of displaying in color, on DVD, pipe inspection observations such as pipe defects, sags, points of root intrusion, offset joints, service connection locations, and any other relevant physical attributes.

DVD Logs. The Contractor is to provide, with each completed DVD, a TV inspection report which is a written log of all pipe defects, sags, points of root intrusion, offset points, service connection locations and condition recorded on a footage basis. This log is to also denote the section being televised, flow and camera direction, position of taps or failures, pipe condition and weather conditions.

## 2.12. Polyethylene Wrapping Material

Polyethylene wrapping material will be used to encapsulate all ductile and cast-iron fittings.

### 2.12.1. General Requirements

Polyethylene wrapping for ductile and cast-iron fittings will consist of a 4 mil tubular section of cross-laminated high-density polyethylene, which has a high dielectric and tensile strength, for use in insulating cast-iron and ductile-iron pipe from the electrolytic action encountered in highly active soils. All iron pipe, fittings, and accessories shall be wrapped with edges overlapped and taped securely with duct tape to provide a continuous wrap to prevent contact between the pipe and the surrounding backfill. Repair all punctures with duct tape to restore the continuous protection before backfilling.

Polyethylene wrapping is to consist of opaque cross-laminated high-density polyethylene sheet continuously thermally bonded to form a tubular section. The tubes may be supplied in bulk length on rolls or in individual pre-cut lengths. See Table 11 for size and length chart, in accordance with AWWA C-105 (Table 1) for minimum requirements. When supplied in specific pipe lengths, the tubes are to contain a minimum of 4-ft. over the actual pipe length to allow for overlap.

The polyvinyl sheet of film for the tubular wrapping is to be of virgin resins meeting raw and physical properties of ASTM D-1248 and AWWA C-105, latest edition. The material is to be 4 mil cross-laminated high-density polyethylene of uniform film thickness and be free of imperfections such as pin holes, etc., after being thermally seamed into tubular form. The finished product will have a nominal thickness of 4 mils, with tolerances of minus ten percent.

The material is to have no volatile constituents, the loss of which may affect ductility. The material is also to have the following properties:

- **Mechanical:** The polyethylene film is to have a tensile strength per latest ASTM D-882 test, of 6300 psi min. The film is to have an elongation of not less than 100% of the test strip per latest ASTM D-882 test. The film is to have an impact resistance 800 gram min per (ASTM D-1709 Method B). The film is to have a propagation tear resistance of 250 gf minimum in machine and transverse direction (ASTM D1922).
- **Dielectric:** The film is to have a dielectric strength of 800 volts per mil thickness per ASTM D-149.

Inspection and Certification by Manufacturer:

- *Quality control and inspection.* The manufacturer shall establish the necessary quality control and inspection practice to ensure compliance with this standard.
- *Manufacturer's statement.* The manufacturer shall, provide a sworn statement on each lot purchased that the inspection and all applicable material requirements of Section 4.1 have been met and that all results comply with the requirements of this standard.
- *Freedom from defects.* All polyethylene film shall be clean, sound, and without defects that could impair service.

### 2.12.2. Marking Requirements

The polyethylene film supplied shall be clearly marked, at a minimum of every 2-ft along its length, containing the following information.

- Manufacturer's name or trademark
- Year of manufacture
- ANSI/AWWA C-105/A21.5
- Minimum film thickness and material type.
- Applicable range of nominal pipe diameter size(s).

- Warning-Corrosion Protection-Repair any Damage.

The City of Converse may at no cost to the Contractor, subject random testing by an independent laboratory for compliance with this Specification. Any visible defect of failure to meet the quality standards herein will be grounds for rejecting the entire order.

Table 11	
4 MIL POLYETHYLENE WRAPPING MATERIALS	
SIZE & LENGTH (All sizes lay flat size)	
Pipe Size	Product Size Width x Length
4", 6" & 8"	20" x 200/500
8", 10" & 12"	27" x 200/500
16" & 18"	37" x 200/500
20"	41" x 200/500
24"	54" x 200/500
30"	67" x 140/500
36"	81" x 120/500
48"	95" x 100/500
54"	108" x 100/500

### 2.13. Air Release Assemblies for Wastewater

Valves furnished under this specification shall conform to ANSI/NSF Standard 60 for direct additives and ANSI/NSF Standard 61 for indirect additives. Cast Iron Valve Body and cover shall be in accordance with ASTM A48-35 or ASTM A126 class B. Non-Metallic Valve Body shall be fabricated from fiberglass reinforced nylon. Inlet sizes through 2 inches shall be screwed (NPT). Pipe sizes 3" and above shall have flanged inlets (125# ANSI B 16.1). A protective hood or cowl shall be installed on the outlet of flange-bodied valves.

Metallic Internal seat trim float arm and pivot pin shall be stainless steel type 303, 304 or 316. Metallic Floats shall be stainless steel ASTM A 240. Other stainless steel metal internal parts shall be stainless steel ASTM A240 or ASTM A276.

Non-metallic floats shall be foamed polyethylene with stainless steel type 316 fasteners.

Valves requiring Internal seats or orifice buttons shall be Buna-N rubber compounded for water service. For valves requiring cover gaskets, the cover gasket shall be composition type, equal to Armstrong CS-231, Garlock 3000, or Lexide NK-511. If an O-Ring is used to seal the cover, it shall be on NSF 61 certified rubber. Cover bolts shall be alloy steel. Rolling seals shall be furnished for non-metallic valves 2" and below.

Valve Body will have a test pressure rating of 300 psi and working pressure rating of 150 psi.

The air release valve shall be designed to vent accumulated air automatically. The outlet orifice shall be properly sized to facilitate valve operation at pressures up to 150 psi. The air release valve shall be simple-lever, compound-lever, ball and orifice or rolling seal depending upon volume requirements and the design of the valve.

The air and vacuum valve shall be designed with the inlet and outlet of equal cross-sectional area where applicable. The valve shall be capable or automatically allowing large quantities of air to be exhausted during the filling cycle an also capable of automatically allowing air to re-enter the system to prevent a negative pressure at water column separation or during the draining cycle. The float shall be guided to minimize premature closure by air and to provide proper alignment for normal closure by floating on the water surface.

Combination air and vacuum relief valves shall provide for both automatic air release under system pressure and to allow air movement during filling or draining operations or water column separation. The combination valve may be housed in a single casting. The housing shall be designed to incorporate conventional or kinetic flow principles to properly vent the air without premature closure. Flanged sized (4 inch and larger) may be furnished in a dual housing. When dual casings are used a bronze manual isolation valve shall be installed if indicated by the manufacturer. This will allow the air release valve to be serviced when the system is under pressure. Field service of the valve may also be performed by closing the isolation valve between the air valve and the pipe connection.

The City of Converse may, at no cost to the manufacturer, subject random valves to testing by an independent laboratory for compliance with these standards. Any visible defect or failures to meet the quality standards herein will be grounds for rejecting the entire order.

The manufacturers shall provide certification that products furnished under this specification are manufactured in an ISO 9001 certified facility or documentation from an accredited facility that ISO 9001 certification is in process.

#### 2.14. Rehabilitation of Lines.

##### 2.14.1. Point Repair Pipe

Pipe Material used for repairs shall be in accordance with Section 2.1 "Sanitary Sewer Pipe". If point repair is located at a service connection, use a full-bodied fitting for the service connection. No field fabrication of fittings allowed.

Joint Material. Use flexible adapters secured with ½ inch stainless steel bands, as manufactured by Fernco, or approved equal. All flexible adapters shall be concrete encased to prevent movement or breakage of the steel bands.

##### 2.14.2. Cast-In-Place-Pipe

This Item shall provide for the reconstruction of existing sewer lines by forming a new pipe within an existing structurally deteriorated pipe which has generally maintained its original shape. The CIPP shall provide flow capacity equal to or greater than 100 percent of the original pipe's flow capacity when new. The installation of the CIPP shall be accomplished by the use of the Insituform Process, Inliner U.S.A., Inc., or approved equal process. The process is defined as the reconstruction of sewer line by installation of a thermosetting resin impregnated flexible felt fiber tube which is inverted into the existing sewer line utilizing a fluid column. Curing is accomplished by circulating hot water, or other approved liquid, throughout the length of the inverted tube to cure the thermosetting resin into a hard, impermeable pipe. The pipe shall extend the full length of the original pipe and shall provide a structurally sound, jointless, close fitting, CIPP.

Patents. The inversion process is patented and is installed by licensed Contractors. The Contractor shall warrant to the owner and the Engineer that the methods, materials and equipment used herein, where covered by license, are furnished in accordance with such license; and the prices included in this proposal include applicable royalties and fees in accordance with such license. The Contractor shall warrant and save harmless the owner of the sewer line (City of Converse) and the Engineer against all claims for patent infringement and any loss thereof.

The Contractor may propose a proven alternate method of CIPP, meeting all criteria of this specification. This alternate approval must come from the City of Converse's Engineer.

The Following information shall be submitted to the Engineer a minimum of twenty days prior to construction operations.

- Product Data Design Criteria
- Physical Properties
- Limitations of Process
- Material Specifications
- List of Current and Previous Projects in USA (with size)
- List of Testing Methods
- Third Party Test Data
- List of References
- List of Currently Owned Equipment

#### 2.14.3. Flexible Felt Fiber Tube.

The resin impregnated felt tube shall be manufactured and fabricated, under quality controlled conditions set by the process manufacturer, to a size that, when installed, will snugly fit the internal circumference of the existing sewer, and provide the required thickness when cured with the liquid thermosetting resin, as described later. The minimum length shall be as found necessary by the Contractor, to effectively and fully span the actual field distance between the manholes, with extra allowance as needed for proper stretching and shrinkage due to pressure, expansion, and for lateral service cuttings, etc. Measurement for payment shall be made from the actual field measurements of distance between the centerlines of the manholes.

#### 2.14.4. Resin.

The liquid thermosetting resin used to impregnate the felt tube shall produce a properly cured tube that will be resistant to abrasion and corrosion due to solids, grit, sand, acids, and gases such as hydrogen sulfide, methane, and carbon monoxide. The resin selected shall have proven resistance to normal municipal sewage, especially sulfuric acid corrosion from hydrogen sulfide gas.

The resin system to be used shall be manufactured by approved companies selected by the CIPP process manufacturer. Relevant information from the resin manufacturer shall include specifications, characteristics and properties, as well as methods of application. This data shall be submitted for approval. A written certification that the resin material complies with the required application, along with curing temperature and duration of the temperature (step cooking temperature or hours at each and final stages) depending upon the sewer size and liner thickness, shall be supplied. A blanket letter may not be sufficient in case of varying liner thickness and lengths, etc. This information is necessary for the Engineer to be satisfied that the curing is being done according to plan and procedure, and it being checked accordingly in the field during installation.

The Engineer shall also be informed, in advance, for verification and inspection of the resin material at the "wet out" of the felt tube. The inspection shall be at the discretion of the Engineer, which shall not relieve the Contractor of responsibility. The inversion and heating schedule or plan shall be submitted at least 24 hours in advance. Heating shall continue uninterrupted until the desired temperature is achieved. Temperatures shall be measured at both ends by sensitive and accurate measuring devices.

Correction of failed liner, deemed unacceptable as a result of post-TV inspection or test reports for structural values, thickness, etc., shall be repaired by the Contractor at the Contractor's expenses. The method of repair shall be as approved, which may require field or workshop demonstration.

The minimum length shall be that deemed necessary by the Contractor to effectively span the distance from the inlet to the outlet of the respective manholes unless otherwise specified. The Contractor shall verify the lengths in the field before impregnation of the tube with resin. Individual inversion runs may be made over one or more manhole sections as determined in the field by the Contractor and as approved.

The outside of the tube, before installation, shall have an impermeable plastic coating. This coating will form the inner layer of the finished pipe and is required for enhancement of corrosion, flow and abrasion properties.

The layers which constitute the pipe wall must be such that when the thermosetting resin cures, the total wall thickness must be homogeneous with no internal layer of plastic which might weaken the pipe wall and allow internal shear. When cured, the CIPP must form a mechanical bond with the pipe.

The materials used shall result in an installed CIPP flow capacity which is equal to or greater than 100 percent of the original pipe's low capacity when new.

The existing sewers, where designated or required, shall be lined using materials and workmanship which can be adapted to the restrictions of the work site. The Contractor shall not begin this phase of the work until sufficient materials are on hand to complete the job.

The Contractor shall furnish to the Engineer, prior to use of the lining material, satisfactory certification from an approved testing laboratory as to the results of testing the proposed lining material.

#### 2.15. Repairs

Pipe materials used for repairs shall be in accordance with Section 2.1 "Sanitary Sewer Pipe".

#### 2.16. By-Pass Pumping

The Contractor shall provide all necessary pumping equipment, piping and all other necessary appurtenances in order to maintain adequate and reliable sanitary sewer flow in the sewer system (excluding manholes) at all times during construction. All materials, equipment, etc., must be in good condition, and should not have visible damage such as cracks, holes, foreign material, blisters, etc.

High-Density Polyethylene (HDPE) is the preferred pipe material for all bypass piping. HDPE must be used when bypass discharge pipe will be going through streams, storm water culverts, the Edward's Aquifer Recharge Zone, and/or environmentally sensitive areas.

- HDPE pipe must be assembled and joined using couplings, flanges or fusion welding in order to avoid joint leakage.
- HDPE fusion welding must be performed by personnel certified as fusion technician(s) by the manufacturer of HDPE pipe and/or fusing equipment.
- By-Pass Pumping Plan shall indicate the proposed DR of the pipe to be used.

Pipe material other than HDPE shall be submitted to the Engineer for approval. Neither "Irrigation type" pipe nor glued PVC pipe will be permitted.

Plugs must be selected and installed according to the size of the line to be plugged. An additional plug must be onsite and ready to be installed in the event a plug fails or becomes dislodged. Plug(s) will be reviewed by the Inspector and/or Engineer for defects that might lead to failure prior to being installed. It is also imperative that the Contractor notify the Inspector at the completion of the work in order to verify that all plugs have been removed from the system.

#### Plugs

- The Contractor shall provide all necessary equipment, plugs, hoses, gauges and necessary appurtenances to install the plug, maintain the plug during use and remove the plug at completion.
- All plugs must be in good condition, and shall not have visible damage such as cracks, holes, tears, cuts, punctures, abrasions, loose or damaged fittings, cracks in castings and excessive wear.
- All plugs 15-inches and larger shall have an air release valve for rupture protection.

- All plugs 24-inches in diameter and larger shall be equipped with a radio transmitter locating device that is activated by the plug losing air pressure. The locating transmitter device shall be effective to a depth of 65 feet, and have a battery life of 1,000 hours when operated in pulse mode after activation.
- All plugs 24-inches in diameter and larger shall have a protective sleeve.
- If the plug is damaged, do not use the plug and remove it from the job site.
- Contractor must be aware of the limitations associated with plugs.

Pumps must be fully automatic self-priming units that do not require the use of foot-valves or vacuum pumps to prime the system. No electric pumps will be allowed; all pumps must be diesel powered. The primary pump must be a grinder or chopper pump, in order to reduce the potential for debris to complicate the safe operation of the pumps. Contractor shall have one backup pump, equal in capacity to the largest pump in the system, connected the bypass pumping system, and ready for operation in case any of the primary pumps fail. The backup pump shall not be used in Contractor's calculations for determining the pumping capacity requirements for the stated flow conditions above. Sound-attenuated pump enclosures shall be required on all projects where the bypass pumps are located within 50 feet of any residence, business, park, or other presence of people.

## 2.17. Pipe Bursting/Crushing Replacement Process

### 2.17.1. High Density Polyethylene Pipe (HDPE)

High Density Polyethylene Pipe (HDPE) related to pipe bursting or pipe crushing for a sanitary sewer or related pipe line rehabilitation:

Solid wall HDPE pipe referred to as Drisco 1000, Drisco 8600, Quail Pipe, Poly Pipe, and Plexco Pipe that is in conformance with ASTM F714 and ASTM requirements stated herein are considered approved for this project. HDPE pipe on this project will further be required to have a minimum pipe stiffness of 46 psi for 12-in. to 48-in. diameter pipe and 115 psi for 8-in. to 10-in. diameters as required by City of Converse and TCEQ.

### 2.17.2. Pipe Manufacturer

All pipe and fittings will be high density polyethylene pipe and made of virgin material. No re-work except that obtained from the manufacturer's own production of the same formulation will be used. The liner material will be manufactured from a High Density High Molecular weight polyethylene compound which conforms to ASTM D 1248 and meets the requirements for Type III, Class C, Grade P-34, Category 5, and has a PPI rating of PE 3408.

The pipe produced from this resin will have a minimum cell Classification of 345434C (Inner wall will be light in color) under ASTM D 3350. A higher number cell classification limit which gives a desirable higher primary property, per ASTM D 3350 may also be accepted by the Engineer at no extra cost to City of Converse. The value for the Hydrostatic Design basis will not be less than 1600 psi (11.03 MPA) per ASTM D 2837. Pipe will have ultraviolet protection.

### 2.17.3. Pipe Color and Quality

For television inspection purposes, the polyethylene pipe will have light-colored interior achieved with a homogenous, light-colored material throughout or with a fully bonded light-colored interior liner meeting specifications indicated above. All pipe will be free of visible cracks, holes, foreign material, foreign inclusions, blisters, or other deleterious or injurious faults or defects. Pipe and fittings shall be as uniform as commercially practical in color, opacity, density, and other physical properties.

For interior lined pipe, the liner will be a minimum of 10 mils thick and co-extruded. The bond between the layers will be strong and uniform. It will not be possible to separate the two layers with a probe or point of a knife blade so that the layers separate cleanly at any point, nor will separation of the bond occur, between layers, during testing performed under the requirements of this specification.

2.17.4. Pipe Diameter

Polyethylene Plastic Pipe will meet the applicable requirements of ASTM F 714 Polyethylene (PE) Plastic Pipe (SDR-PR) Based on Outside Diameter, ASTM D 1248, and ASTM D 3550. Internal diameter of the pipe indicated on the plans will be the minimum allowable pipe size.

2.17.5. Pipe Dimension Ratios

The minimum wall thickness of the polyethylene pipe will meet the following, as based on the deepest portion of a particular pipe pull, typically between manholes:

<u>Depth of Cover (Feet)</u>	<u>Minimum SDR of Pipe</u>
0-16.0	19
>16.1	17

Wall thickness shall be as indicated on the plans and will be in accordance with Chevron Plexco Industrial Piping System Pipe Data and Pressure Rating Bulletin 301, or approved equal.

2.17.6. Pipe Joining

Solid wall pipe shall be produced with plain end construction for heat-joining (butt fusion) conforming to ASTM D 2657.

The polyethylene pipe will be assembled and joined at the site using the thermal butt-fusion method to provide a leak proof and structurally sound joint. Threaded or solvent-cement joints and connections are not permitted. All equipment and procedures used will be used in strict compliance with the manufacturer's recommendations. Fusing will be accomplished by personnel certified as fusion technicians by a manufacturer of polyethylene pipe or fusing equipment.

The butt-fused joint will be true alignment and will have uniform roll back beads resulting from the use of proper temperature and pressure. The joint surfaces will be smooth. The fused joint will be watertight and will have tensile strength equal to that of the pipe. All joints will be subject to acceptance by the Engineer or his representative prior to insertion. All defective joints will be cut out and replaced at no cost to City of Converse. Any section of the pipe with a gash, blister, abrasion, nick, scar, or other deleterious fault greater in depth than ten percent of the wall thickness, will not be used and must be removed from the site. However, a defective area of the pipe may be cut out and the joint fused in accordance with the procedures stated above. In addition, if in the opinion of the Engineer or his representative any section of pipe has other defects, including those hereinafter listed, that may indicate damaged, improperly manufactured, faulty, or substandard pipe, said pipe will be discarded and not used. Defects warranting pipe rejection include the following: concentrated ridges, discoloration, excessive spot roughness, and pitting; insufficient or variable wall thickness; pipe damage from bending, crushing, stretching or other stress; pipe damage that impacts the pipe strength, the intended use, the internal diameter of the pipe, internal roughness characteristics; or any other defect of manufacturing or handling.

Clamps and Gaskets. Clamps shall be stainless steel, including bolts and lugs as manufactured by JCM Industries Type 108 or equal. Furnish full circle, universal clamp couplings with a minimum 3/16-in. thick neoprene, grid-type gasket. Select Clamps to fit outside diameter of pipe. Use minimum clamp length of 30-in. for replacement pipe O.D. of 10.75-in. (10 inch nominal) or greater, and 18-in. for replacement pipe O.D. less than 10.75-in.

Terminal sections pipe that are joined within the insertion pit will be connected with a full circle pipe repair clamp. The butt gap between pipe ends will not exceed 1/2-in.

## 2.17.7. Force Mains

Where applicable, solid wall pipe for sanitary sewer force mains shall have a minimum working pressure rating of 150 psi, and an inside diameter equal to or greater than the nominal pipe size indicated on the Drawings.

## 2.17.8. Augering Pipe

HDPE pipe is not approved in applications requiring augering of sewer pipe.

## 2.17.9. Pipe Marking

Each standard and non-standard length of pipe or fitting shall be clearly marked with pipe size, pipe class, production code, material designation and other relevant identifying information.

## 2.17.10. Pipe Inspections

The Engineer and/or Inspector reserves the right to inspect pipes or witness pipe manufacturing. Such inspection shall in no way relieve the manufacturer of the responsibilities to provide products that comply with the applicable standards and these Specifications. Should the Engineer and/or Inspector wish to witness the manufacture of specific pipes, the manufacturer shall provide the Engineer and/or Inspector with adequate notice of when and where the production of those specific pipes will take place. Approval of the products or tests is not implied by the Engineer and/or Inspector's decision not to inspect the manufacturing, testing, or finished pipes.

## 2.18. Sliplining.

## 2.18.1. Manufacturers

Liner pipe systems shall be fiberglass reinforced plastic (FRP) or T-Lock Liner concrete pipe, as approved by the City of Converse.

Acceptable manufacturer for FRP liner pipe: Shall conform to the current Standard Material Specifications accepted by City of Converse.

Acceptable manufacturer for Amer-Plate T-Lock pipe: Ameron Protective Linings.

## 2.18.2. FRP Liner Pipe and Fittings

Pipe, joint and fitting; ASTM D 3262m Type 1, Liner 2, Grade 3.

FRP Liner Pipe: Reinforced plastic mortar pipe manufactured by centrifugal casting process resulting in dense, nonporous, corrosion-resistant, consistent, composite structure. Minimum Stiffness: 72 psi, measured in accordance to ASTM D 2412. use with a stiffness of 72 psi where specified or shown on the drawings.

Resin Systems: Thermosetting polyester epoxy resin, with or without filler, meeting ASTM D 3262.

Reinforcing Glass Fibers: Commercial Grade E-type glass filaments, with binder and sizing compatible with impregnating resins.

Filler: Sand with at least 98 percent silica content, and maximum moisture content of 0.2 percent.

Joints: Low-profile FRP jacking bell-and-spigot joints or flush bell and spigot joints, with elastomeric sealing gaskets for watertight joints meeting ASTM D 4161.

Dimensions and Tolerances:

- Pipe outside diameters and tolerances: Comply with ASTM D 3262, Cast Iron Pipe Equivalent Outside Diameters, and table below.
- When possible, supply pipe in nominal lengths of 20-ft. Where radius curves in existing pipe or limitations in entry pit dimensions restrict pipe length, shorter lengths may be used.
- FRP pipe minimum outside diameters and minimum wall thickness:

Minimum Existing Sewer Nominal Diameter	Minimum Wall Liner O.D.	Minimum Wall Thickness	Thickness
		46 p.s.i.	72 p.s.i.
		Stiffness	Stiffness
<u>(Inches)</u>	<u>(Inches)</u>	<u>(Inches)</u>	<u>(Inches)</u>
21	19.50	0.42	0.48
24	21.60	0.46	0.53
30	25.80	0.54	0.63
36	32.00	0.66	0.77
42	38.30	0.78	0.91
48	44.50	0.90	1.05
54	50.80	1.02	1.19
60	57.10	1.14	1.33
66	62.90	1.26	1.47
72	69.20	1.38	1.61
78	75.40	1.50	1.75

- Fabricate pipe ends square to pipe axis plus or minus 0.25-in., or plus or minus 0.5 percent of nominal diameter, whichever is greater.

#### Fittings.

- Flanges, elbows, reducers, tees, wyes, and other fittings: Capable of withstanding operating conditions.
- Fabrication: Contact-molded or manufactured from mitered sections of pipe joined by glass-fiber-reinforced overlays.

#### 2.18.3.

##### Liner Pipe Seals at Manholes.

Sealer for annular spaced between liner pipes and host sewers at manholes: Oakum strips soaked in Scotchseal 5600 as manufactured by 3M Corporation, or approved equal.

Non-Shrink Grout: Strong Seal's QSR patching material or approved equal.

## 2.18.4. Clamps and Gaskets.

Clamps: Stainless steel, including bolts and lugs, as manufactured by JCM Industries, Type 108, or equal. Furnish full circle, universal clamp couplings with at least 3/16-in. thick neoprene grid-type gaskets. Select clamps to fit outside diameter of liner pipe as follows.

Liner Pipe O.D. (Inches)	Minimum Clamp Length (Inches)
7.125	15
8.625	18
10.750 greater	30

## 2.18.5. Bedding Material.

Make point repair and remove obstructions, such as roots, rocks and other debris, prior to installing liner pipe. Comply with excavation, trenching, and backfill requirements of this specification.

## 2.19. Sliplining Grout

## 2.19.1. Manufacturers/Application

The applicator of the grout mix shall be certified by the grout mix manufacturer and approved by the City of Converse Engineer. The certified applicator shall be regularly engaged in the placement of grout, including completion of pipeline grouting installations having at least 1000 cubic yards in the past 3 years.

## 2.19.2. Materials

2.19.2.1. Cement: Comply with ASTM C 150. Pozzolans and other cementitious materials are permitted.

2.19.2.2. Fly Ash: Comply with ASTM C 618; either Type C or Type F shall be used.

2.19.2.3. Sand, if provided, shall conform to ASTM C 144, except as modified below:

U.S. Standard Sieve Size	Percent Passing By Weight
No. 16	100
No. 30	60 – 85
No. 50	10 – 35
No. 100	5 – 25
No. 200	- 10

2.19.2.4. Water: Use potable water free from deleterious amounts of alkali, acid, and organic materials which would adversely affect the setting time or strength of the slip-lining grout.

2.19.2.5. Admixtures: Admixtures shall be selected by the slip-lining grout manufacturer to meet performance requirements, improve pumpability, control set time and reduce segregation.

- 2.19.2.5.1. Compressive Strength. The grout shall have a minimum penetration resistance of 100 psi in 24 hours when tested in accordance with ASTM C 403 and a minimum compressive strength of 300 psi in 28 days when tested in accordance of ASTM C 495 or C 109.
- 2.19.2.5.2. Performance Requirements. The Contractor shall submit the proposed grout mixes, methods, plans and criteria of the grouting operations. The grouting system shall have sufficient gauges, monitoring devices, and test to determine the effectiveness of the grouting operation and to ensure compliance with the liner pipe specifications and design parameters.
- 2.19.2.5.3. Mix Designs. One or more mixes shall be developed to completely fill the annular space based, but not restricted to, the following requirements:
  - Size of annular void
  - Void (size) of the surround soil
  - Absence or presence of groundwater
  - Sufficient strength and durability to prevent movement of the line pipe.
  - Provide adequate retardation, and
  - Provide less than 1 percent shrinkage by volume.
- 2.19.2.5.4. Density/Viscosity. The Contractor shall design a grout mix with a density to prevent floating of the liner pipe. The apparent viscosity shall not exceed 20 seconds in accordance with ASTM C 939 unless otherwise approved by the City of Converse engineer.

2.20. Bedding and Backfill

Backfilling for sanitary sewers is divided into three (3 separate zones: (a) bedding: the material in trench bottom in direct contact with the bottom of the pipe; (b) initial backfill: the backfill zone extending from the surface of the bedding to a point 1 foot above the top of the pipe; and (c) secondary backfill: the backfill zone extending from the initial backfill surface to the top of the trench. Materials and placement for each of the zones shall be as described herein.

2.20.1. Bedding.

Stable Material: Existing stable material present during excavation including:

Trench bottom free of water, muck, debris;

Rock in boulder, ledge or coarse gravel (particle size not larger than 1- 3/4 inch) formations;

Coarse sand and gravels with maximum particle size of 1- 3/4 inch, various graded sands and gravels containing small percentages of fines, generally granular and non-cohesive either wet or dry; and

Fine sands and clayey gravels; fine sand, sand-clay mixtures, clay and gravel-clay mixtures.

Unstable Material: Existing unstable materials are: Silt, muck, trash or debris in the trench bottom bearing level; rock, in ledge or boulder, or coarse gravel (minimum particle size larger than 1- 3/4 inch) formations.

Bedding Material: The existing material at the bearing level shall be removed and replaced to a minimum depth of 6 inches or 1/8 of the outside diameter of the pipe, whichever is greater, with bedding material. The bedding material shall extend up the sides of the pipe sufficient to embed the lower quadrant of the pipe. The bedding material shall be composed of well-graded, crushed stone or gravel conforming to the following requirements unless modified by the Engineer in writing.

<u>Sewer Gravel</u>	<u>Percent</u>
Passing 1-1/2 inch sieve	100
Passing 1 inch sieve	95 – 100

Passing 1/2 inch sieve	25 – 60
Passing No. 4 sieve	0 – 10
Passing No. 8 sieve	0 – 5

Over Excavation: Where the trench bottom has been over excavated beyond the limits as defined in the "Sanitary Sewers," section described herein due to removal of unstable material, the pipe shall be concrete-encased. Encasement shall extend from the trench wall to trench wall and be a minimum of 6 inches above the top of pipe. No separate pay item.

Reduced Excavation: Where the trench bottom is not excavated in accordance with the specification due to rock or other hard under lying materials, then the pipe shall be concrete encased. No separate pay item.

Consolidating Backfill Material: The Initial Bedding material shall be consolidated to assure it is incorporated from the bottom of the trench up to the pipe centerline. A hand-held vibrator, commonly used for concrete work, can be used for this purpose. The vibrator shall be inserted every 3 feet on each side of the pipe.

#### 2.20.2. Initial Backfill

Initial backfill is defined as backfill having a thickness in its compacted state from the surface of the bedding to a point 1 foot above the top of the pipe.

Initial backfill shall consist of gravel which conforms to the requirements for bedding material.

#### 2.20.3. Secondary Backfill

Secondary backfill is defined as backfill from 1 foot above the top of the pipe to the top of the trench or bottom of pavement section. Secondary backfill shall be constructed in accordance with details shown in the construction documents.

Secondary backfill shall generally consist of materials removed from the trench and shall be free of brush, debris and trash. Rock or stones having a dimension larger than 6 inches at the largest dimension shall be sifted out and removed before the material is used in the secondary backfilling zone. Secondary backfill material shall be primarily composed of compactible soil materials.

The secondary backfill material shall be placed in maximum 12 inch loose lifts or as directed by the Design Engineer and/or Inspector.

---

### 3. CONSTRUCTION

#### 3.1. Excavation

Excavation as required to complete the work as outlined herein will be performed in accordance with Item 400, "Excavation and Backfill for Structures".

##### 3.1.1. Trench Excavation Protection

Excavation greater than 5-ft. in depth is to be protected as specified in Item 402, "Trench Excavation Protection", or Item 403, "Temporary Special Shoring".

##### 3.1.2. Trenches

Trench walls shall be vertical. The practice of undercutting at the bottom or flaring at the top will not be permitted except where it is justified for safety or at the Engineer and/or Inspector's direction. In special cases, where trench flaring is required, the trench walls shall remain vertical to a depth of at least 1 foot above the top of the pipe.

The trench bottom shall be square or slightly curved to the shape of the trenching machine cutters. The trench shall be accurately graded along its entire length to provide uniform bearing and support for each section of pipe installed upon the bedding material. Bell holes and depressions for joints shall be dug after the trench bottom has been graded and bedding installed. The pipe shall rest upon the new bedding material for its full length.

Where over-excavation occurs and when not as directed by the Engineer and/or Inspector, the under-cut trench shall be restored to grade at no cost to City of Converse by replacement with a material conforming to the requirements of the bedding material or a material approved by the Engineer and/or Inspector.

### 3.2. Width of Trench

Minimum Width of Trench. The minimum width of pipe trenches, measured at the crown of the pipe, shall be not less than 12 inches greater than the exterior diameter of the pipe, exclusive of bells. The minimum base width of such trench shall be not less than 12 inches greater than the exterior diameter of the pipe, exclusive of special structures or connections. Such minimum width shall be exclusive of trench supports and not greater than the width at the top of the trench.

Maximum Width of Trench. The maximum allowable width of trench for pipelines measured at the top of the pipe shall be the outside diameter of the pipe (exclusive of bells or collars) plus 24 inches. A trench wider than the outside diameter plus 24 inches may be used without special bedding if the Contractor, at his sole expense, furnishes pipe of the required strength to carry additional trench load. Such modifications shall be submitted to the Inspector and approved in writing. Whenever such maximum allowable width of trench is exceeded, except as provided for in the contract documents, or by written approval of the Engineer, the Contractor, at his sole expense, shall encase the pipe in concrete from trench wall to trench wall, or with other approved pipe bedding material. Any excavation wider than this maximum width or subsequent surface or paving work, will be done at the Contractor's sole expense.

#### 3.2.1. Classification of Excavated Materials

No classification of excavated materials will be made. Excavation and trench work is to include the removal and subsequent handling of all materials excavated in accordance with Item 400, "Excavation and Backfill for Structures".

#### 3.2.2. Grade of Trench Bottom

The trench is to be over-excavated to a depth of 6-in. below the grade line established for the bottom of the pipe, regardless of the type of pipe. The grade line of the pipe is to then be met by the addition of a layer of approved bedding material as directed.

#### 3.2.3. Excavation Below Grade

Any part of the bottom of the trench excavated below the limits specified in Section 3.1.4., "Grade of Trench Bottom", is to be corrected with approved material and compacted as directed. Should excessive over-excavation occur, except at bell holes, the grade is to be restored in accordance with the methods described in Section 3.1.6, "Unstable Conditions at Grade", at no cost to the Department or the City of Converse.

#### 3.2.4. Unstable Conditions at Grade

Where the bottom of the trench at grade is found to be unstable or to include ashes, cinders, any type of refuse, vegetable or other organic material, or large pieces of fragments or inorganic materials which in the judgment of the Engineer and/or Inspector should be removed, the Contractor is to excavate and remove such unsuitable material to a depth no less than 6-inches below pipe. Before the pipe is laid the grade is to be restored by backfilling with an approved material in layers of 3-in. prior to compaction. The layers are to be slightly moistened and thoroughly compacted so as to provide a uniform and continuous bearing and support for the pipe at every point between bell or collar holes. The finished grade is to be accurately graded to provide uniform bearing and support for each section of pipe at every point along its entire length except

for the portions of the pipe sections where it is necessary to excavate for bell holes and for the proper seating of pipe joints.

### 3.2.5. Caution in Excavation

The Contractor is to proceed with caution in the excavation and preparation of the trench so that the exact location of underground structures and utilities may be determined whether shown on the plans or not. Machine excavation is not permitted closer than 12-in. on either side of other existing underground utilities. The Contractor is to be responsible for the repair of such structures and utilities when broken or damaged. He is also to be responsible for adjusting alignment and trench grades with reference to such structures in order to obtain specified clearance for the sewer main construction.

Whenever the Engineer and/or Inspector determines that it is necessary to explore and excavate to determine the location of existing underground structures and utilities, the Contractor is to make explorations and excavations for such purposes at his expense. Backfill Material Derived from Excavation.

Any excess excavated material, not utilized after all fill requirements have been met, shall become the responsibility of the Contractor. The Contractor shall dispose of it by hauling and wasting outside the limits of the rights-of-way or easements of this project and of public thoroughfares and water courses, in conformity with pertinent City, County, State and Federal codes and ordinances and in a manner meeting the approval of the Engineer and/or Inspector.

### 3.2.6. Trench Restoration

The surface of the backfilled trench shall be restored to match the previous existing conditions. This shall include final grading, placement of topsoil and seeding, placement of sod (such as at homes or businesses that had maintained grass), or other unprepared and prepared surfaces.

Trenches in alleys actively being used by vehicles (such as trash pickup, vehicle parking, etc.) shall be restored by grading and compacting to 98% or higher with a minimum of 4 inches of flexbase materials for the entire width of the alley. Asphaltic materials shall have a compaction density of 95%. Alleys not actively used by vehicles shall be graded and compacted to 98% or higher from the top of the initial backfill to the bottom of the pavement section, then spread grass seed for entire width of the alley.

Trenches in paved streets shall be covered with a temporary all weather surface to allow for vehicular traffic until the final asphalt/concrete paving is complete. This surface shall be a minimum of 4 inches compacted and rolled asphaltic black base, either hot-mix or cold-mix applied. It is the Contractor's responsibility to maintain this surface until the final street restoration is complete. Temporary street striping may also be required. This surface must be removed prior to final asphaltting.

All street work shall be done in accordance with the latest TXDOT construction specifications. Included in this requirement is replacement of any curbs or sidewalks damaged or removed during the construction.

No separate payment for the surface restoration is permitted. The cost for this work must be included in the appropriate bid item.

### 3.2.7. Pavement.

The Contractor is to remove pavement and surfaces as a part of the trench excavation. The removal of pavement and surfaces and their restoration is to be based on the minimum trench widths as specified, plus 6-in. either side or as otherwise provided herein. The Contractor is to use such methods as sawing, drilling, or chipping to assure the breaking of the pavement along straight lines.

If the Contractor removes or damages pavement or surfaces beyond the limits specified above, such pavement and surfaces are to be restored at the expense of the Contractor.

Where water line construction necessitates cutting through existing streets outside the limits of new street construction, said streets are to be replaced in kind as directed. Where, in the opinion of the Engineer and/or Inspector, it is necessary to maintain traffic across a trench, the Contractor is to install temporary metal bridges as necessary to facilitate the movement of traffic.

The street surface adjacent to the trench is to be kept free of surplus spoil. Construction materials are to be placed at locations that will minimize interference with the traveling public.

### 3.2.8. Concrete Sidewalks, Driveways, Etc.

All concrete sidewalks, driveways, etc., are to be cut with a concrete saw. When transverse expansion or "dummy" joints are encountered, the concrete is to be removed to the nearest transverse joint on each side of the trench and restored. The depth of cut is to be such that upon removal of the concrete, the sides of the cut are to be straight and square.

Existing reinforcing wire fabric or bars are to be cut and removed to permit completion of trench excavation, pipe laying, and backfill operations. When the backfill operations have been completed, the existing reinforcement is to be replaced in its original position and satisfactorily spliced prior to the replacement of concrete over the new trench alignment.

Transverse "dummy" joints are to be made by a jointing tool or other means acceptable, and are to match in depth and thickness in the existing transverse joints.

Expansion joint material is to be provided where new construction abuts the existing curb or driveway if the Engineer and/or Inspector deems it necessary.

Concrete is to be spaded, tamped, and thoroughly compacted until mortar entirely covers the surface and has a monolithic finish. The top surface is to be floated, troweled, and finished to match the existing concrete surface.

Immediately after finishing, the concrete surface is to be protected by a membrane compound curing agent, or by wetted cotton or burlap mats. Either method is to be subject to approval.

### 3.2.9. Dewatering.

Prevent surface water and subsurface or ground water from flowing into excavations and from flooding project site and surrounding areas.

The contractor shall not allow water to accumulate in excavations or at subgrade level. Remove water to prevent softening of foundation bottoms and soil changes detrimental to stability of subgrades and foundations. Provide and maintain dewatering system components necessary to convey water from excavations.

Convey water removed from excavation and rainwater to collecting or runoff areas away from buildings and other structures. Establish and maintain temporary drainage ditches and other diversion outside excavation limits. Do not use trench excavations as temporary drainage ditches.

Dewatering devices shall be provided by the Contractor with filters to prevent the removal of fines from the soil.

Should the pumping system draw fines from the soil, the Engineer and/or Inspector shall order immediate shutdown, and remedial measures will be responsibility of the Contractor.

Upon completion of the dewatering work, the Contractor shall remove all equipment and leave the construction area in a neat, clean, condition that is acceptable to the Owner.

The Contractor shall maintain ground water table at least 12 inches below the finished excavation subgrade.

Dewatering Performances. Performances of the dewatering system for lowering ground water shall be measured by observation wells on piezometers installed in conjunction with the dewatering system, and these shall be documented at least daily. The Contractor shall maintain a log of these readings and submit them to the Owner.

No direct payment shall be made for costs associated with dewatering. All costs in connection therewith shall be included in the applicable contract price for the item to which the work pertains.

### 3.2.10. Bedding and Backfill

#### 3.2.10.1. General

Trenches shall not be backfilled until the construction structures or appurtenances, as installed, conform to the requirements specified. Where specified, only the secondary backfilling may incorporate excavated materials approved for backfilling, consisting of earth, loam, sandy clay, sand and gravel, soft shale or other approved materials, free from large clods of earth or stones. Where pipe is specially coated or sleeve/tape wrapped for protection against corrosion, care shall be taken not to damage the coating or sleeve/tape wrap.

Where a trench has been improperly backfilled, or where settlement occurs, the identified section shall be excavated to a depth and length 50 feet beyond the failed area, then refilled and compacted to the grade and compaction level required. The use of sand backfill shall not be allowed. All compaction within the secondary backfill zone shall be such that the apparent dry density of each layer shall be not less than 98% from the top of the initial backfill to the bottom of pavement section. The pavement (asphalt) section shall have 95% compaction density with a maximum dry density at + or - 2% optimum moisture content as determined by tests on samples as outlined in the latest provisions of TX-DoT Testing Method Tex 113-E or most applicable approved equal provisions, unless otherwise shown on the contract documents. At the time of compaction, the water content shall be at optimum moisture content, + or - 2% points.

#### 3.2.10.2. Initial Backfill

Prior to laying the pipe, the normal or select bedding material will be shaped to conform to the outside diameter of the pipe as shown on the plans. Bedding material shall be consolidated to assure it is incorporated from the bottom of the trench up to the pipe centerline. A hand-held vibrator, commonly used for concrete work, can be used for this purpose. The vibrator shall be inserted every 3 feet on each side of the pipe.

For sewer lines up to 24 inches in diameter initial backfill material shall be placed in two lifts above the bedding material the pipe is set on. The first lift shall be spread uniformly and simultaneously on each side and under the bottom quadrant of the pipe to the midpoint or spring line of the pipe. Consolidate the Initial Backfill material as specified for bedding.

Placement of the first lift of initial backfill shall be subject to inspection and approval prior to placement of second lift, which shall extend from the spring line of the pipe to a minimum of 1 foot above the top of the pipe. The second lift shall be evenly spread in a similar manner as the first lift.

For diameters 24 inches and larger, initial backfill material shall be evenly and simultaneously spread alongside, under the lower quadrant the pipe and over the pipe in 12 inch lifts to a point sufficient to a minimum of 1 foot above the top of the pipe. Consolidate the Initial Backfill material as specified for bedding.

#### 3.2.10.3. Secondary Backfill

The secondary backfill material shall be placed in maximum 12 inch loose lifts or as directed by the Engineer and/or Inspector.

### 3.3. Pipe Installation

#### 3.3.1. General

All sanitary sewer mains shall be constructed in accordance with the specifications herein outlined and in conformity with the required lines, grades, and details shown on the plans and as directed by the Engineer and/or Inspector. Successful passage of the air and mandrel test (for flexible pipe, 30 days after installation), as described under TCEQ 30 TAC 217.53 Criteria, shall be required for the acceptance of the mains.

After the trench has been carefully graded and all bell holes excavated, approval is required prior to placing the pipe therein.

All sewers are to be laid in straight alignment, so that a light can be seen from one manhole to the other even for the smaller size of sewers. The pipe is to be laid accurately to line and grade, with the spigot end downstream entering the bell to full depth and in such a manner as not to drag earth into the annular space. Pipes and fittings are to be fitted together and matched so that they will form a sewer with a smooth and uniform invert. Special care is to be taken to provide uniform bearing for the entire length of pipe.

Water Main Crossings: Where gravity or force main sewers are constructed in the vicinity of water mains, the requirements of the TCEQ 30 TAC 217.53 (d), shall be met.

Pipe and Fittings. Proper and suitable tools and appliances for the safe and convenient handling of the pipe and fittings are to be provided and used. Care is to be taken to prevent any damage to the pipe coating. All pipe and fittings will be examined for defects right before placing into the trench and no materials are to be laid that are known to be defective.

Any defective pipe discovered after being laid is to be removed and replaced with acceptable pipe at the Contractor's expense. Wherever the pipe requires cutting, it is to be done with a standard wheel pipe cutter for pipe 12-in. and smaller. Cutting methods for larger pipes are to be as approved. Each cut is to be smooth and at right angles to the axis of the pipe.

Pipe Laying: The Contractor shall be required to commence construction and laying of pipe at the downstream end of the sanitary sewer outfall line and proceed non-stop in a forward upstream direction.

No pipe shall be laid within 10 feet of any point where excavation is in progress. Pipe laying shall proceed upgrade with the tongue or spigot pointing in the direction of flow. Pipe shall be lowered into the trench without disturbing the prepared foundation or the trench sides.

The drilling of lifting holes in the field will not be permitted. Pipe shall be installed by means of a concentric pressure being applied to the pipe with a mechanical pipe puller. Pulling or pushing a joint of pipe in place by using a crane, bulldozer, or backhoe will not be permitted. Pipe shall be pulled home in a straight line with all parts of the pipe on line and grade at all times. No side movement or up and down movement of the pipe will be permitted during or after the pulling operation.

Should coupled joints of pipe be out of line or off grade, they shall be removed one joint at a time and brought to the proper line and grade. The lifting or moving of several joints of coupled pipe at one time to close a partially open joint or to fine grade under laid joints of pipe will not be permitted.

Laser Beams: The use of laser Beams for vertical control shall be required provided the Contractor makes available to the Inspector, when requested, a level and rod of sufficient sensitivity to accurately determine differences in elevation between points 300 feet apart with one instrument set-up. Contractor shall provide a written summary to the Inspector of all elevations that all installed, repaired, or replaced sewer main enter and exit a manhole or structure.

No pipe shall be installed in tunnels except as provided on the plans, or with the permission of the Engineer and/or Inspector. If the Contractor finds it necessary to install pipe in tunnels not provided on the plans, he

shall submit to the Engineer and/or Inspector, prior to commencement of work, a detailed outline of procedures, methods, and use of materials depending on existing soil conditions.

No horizontal or vertical curves shall be permitted in conformance with appropriate regulatory agency requirements.

Before leaving the work unattended, the upper ends of all pipelines shall be securely closed with a tight fitting plug or closure. The interior of laid pipe shall be kept free from dirt, silt, gravel, or foreign material at all times. All pipes in place must be approved before backfilling.

When replacing an existing system in place, Contractor shall maintain screens to prevent the entrance of construction debris into the sewer system.

Pipe Separation: Sewer pipe separation distances shall be maintained in accordance with TCEQ rules 30 §217.53.

### 3.3.2. Service Connections (Sanitary Sewer Laterals)

Sanitary sewer laterals fittings and appurtenances shall conform to the Sanitary Sewer specifications and shall be installed by the Contractor as specified herein, or as directed by the Engineer and/or Inspector and in accordance with the plans. Where the lateral is within the Edwards Underground Recharge Zone then it shall be installed in accordance with details.

Service line Installation: All service line installations shall be performed in accordance with this specification. For sanitary sewer mains that are 12" in diameter or smaller, all laterals shall be connected using the appropriate size tee/wye placed in line with the main line. For mains larger than 12", insert-a-tee conforming to ASTM 3034-88 or approved or equal may be used. Where waterline crossings with sanitary sewer laterals are less than the regulated separation distances, all lateral piping shall be SDR-26 PVC pipe (ASTM D2241-09) with a pressure rating of 150 psi.

Connection to the customer's end of the lateral shall be performed using a flexible coupling, or pre-approved equal. All flexible couplings shall be concrete-encased to prevent movement or breakage of the steel bands. All cleanouts at job sites shall have installed an approved heavy duty sanitary sewer cap.

Cutting, excavation, and backfill shall be as specified herein.

Service Connections:

- Provide reconnections of all existing sewer service laterals to new lines installed or to provide connections of new laterals to existing sanitary sewer mains. Locate laterals and insure service is not interrupted to homes or other establishments.
- Wyes, bends, tees, stacks, and other hardware required are to be installed for service laterals as shown on the plans or as directed.

### 3.3.3. HDPE Pipe Joining

Bending of HDPE pipe will be done in accordance with the manufacturer's instructions.

### 3.3.4. Pipe Joint Restraint System for HDPE Pipe

Restraint devices will be used where ductile iron mechanical joint bell fittings are coupled to plain-end (square-cut) HDPE pipe, to prevent movement of pipe connections. Mechanical joint adapters will be required for the HDPE pipe.

All restraint devices will be installed in accordance with the manufacturer's instructions.

### 3.3.5. Coating and Wrapping Underground Steel Pipe

Exterior surfaces of all steel pipe fittings and specials which are to be installed underground and which are not to be encased in concrete will be cleaned to bare metal by wire brushing with a power driven wire brush, sand blasting, or other approved methods. A prime coat compatible to the polyvinyl tape to be used will then be applied to the pipe. Following the application of the prime coat, the pipe will be wrapped with Scotchrap, Trantex V-10 polyvinyl tape, or approved equal. The tape will not be applied until the prime coat is completely dry.

The tape will be spirally and tightly wrapped on each section of the pipe with a 50 percent lap. The joint will be protected with tape 8-in. in width on pipe greater than 12-in. in size.

Each section of pipe will be cleaned, primed, and wrapped to within 6-in. of each end. The priming and wrapping will be completed, and the bare pipe wrapped with tape lapped 3-in. over the originally taped sections.

### 3.3.6. Protective Coating and Wrapping on Joints

All bolts and nuts installed for underground service on cast-iron mechanical joint fittings and other ferrous metal appurtenances will be packed in an approved protective coating material after installation. After the joint has been made and bolts drawn to proper tension, the joint including glands, flanges, bolt heads, and nuts shall be covered with an approved City of Converse coating. Coating and wrapping of joints will be considered subsidiary to the installation and will not be paid for directly. Asphaltic material such as Talcote shall not be used.

### 3.4. Manhole Construction

Manhole construction is to be in accordance with Item 465, "Manholes and Inlets", and as specified herein.

Footings or bases of manholes shall be a minimum of 6 inches in depth below the bottom of the pipe.

All invert channels of manholes are to be constructed and shaped accurately so as to be smooth, uniform and cause minimum resistance to flow. The bench is to be finished smooth with a slope of 1/2-in./ft. from the manhole walls to the edges of the invert. The top half of all sewer pipes within the invert channel or bench zone are to be removed flush to the inside manhole walls.

Joints on sewer pipes are not to be cast or constructed within the wall sections of manholes.

Concrete cradles are not required for new pre-cast manholes. Concrete cradles are to be provided for all influent and effluent pipes on new monolithic manhole and sewer pipe systems. Concrete cradles are to extend beyond the outside walls of the manhole a minimum of 36-in.

Voids between exterior pipe walls and manhole walls at all pipe connections in manholes shall be filled with a non-shrink grout, concrete or mortar, as approved by the Engineer and/or Inspector or as shown in the contract documents and inspected prior to backfilling.

Where connections to existing manholes are required, the adjacent pipe bedding is to be prepared to proper grade, the existing manhole neatly cut and the new pipe inserted so that the end is projecting 2-in. from the inside wall. The invert is then to be reshaped to properly channel new flows. Debris of any kind is to be kept out of new or existing manholes or mains.

Throat rings shall be mortared between all bearing surfaces sufficient to provide a minimum, in place, mortar thickness of 1/4 inch. No more than 4 throat rings may be used on any manhole or no more than 21 inches from the top of the cone to the top of the ring and cover.

Manhole Ring Encasement. All manhole rings are to be encased with 4,000 psi reinforced Class B concrete as shown on the plans or approved by the Engineer and/or Inspector. Manhole ring encasements are to extend 6-in below the top of the cone and have a minimum thickness when measured at the manhole ring of 1-ft. The surface of the encasement is to be 4-1/2-in. below the top of the manhole ring as shown on the plans or as approved.

Where manholes are constructed in existing or proposed roadways and where directed or shown on the plans, the exterior exposed surfaces of the ring, mortar, throat rings, and manhole surface are to be coated with a 1/8-in. minimum thickness of mastic or plastic prior to placement of concrete.

### 3.5. Manhole Rehabilitation

Described are procedures for cleaning, preparation, application, and testing. The applicator, approved and trained by the manufacturer, shall furnish all labor, equipment and materials for applying a cementitious mix to form a monolithic liner of a minimum 1/2-in. thickness, with machinery specially designed for the application. All aspects of the installation shall be in accordance with the manufacturer's recommendation and as per this specification, which includes:

- the removal of any loose and unsound material,
- cleaning of the area to be restored with high pressure water,
- repair and filling of voids,
- repair and sealing of invert and benches,
- elimination of active infiltration prior to making the application, and
- spray application of a cementitious mix to form a structural or structurally enhanced monolithic liner.

Certification: Manufacturer shall certify that applicator has been trained and approved in the handling, mixing and application of the products to be used. Equipment to be used for applying the products by the Applicator shall be certified and approved by the Manufacturer. Five recent references of Applicator indicating successful application of proposed liner on projects of similar size and scope shall be submitted by Contractor.

Surface Preparation: Proper surface preparation procedures must be followed to ensure adequate bond strength to any surface to be coated. Applicator shall inspect all surfaces specified to receive a liner prior to surface preparation. Applicator shall notify Owner of any noticeable disparity in the surfaces which may interfere with the proper preparation or application of the repair mortar or liners. Concrete that is not sound or has been damaged by chemical exposure shall be removed to a sound, concrete surface. All containments, including: All oils, grease, incompatible existing coatings, waxes, form release, curing compounds, efflorescence, sealers, salts, or other contaminants shall be removed. Surface preparation methods should be based upon the condition of the substrate and the requirements of the liner to be applied.

Surface to receive liner shall be cleaned and abraded to produce a sound concrete surface with adequate profile and porosity to provide a strong bond between the protective coating and substrate. High pressure cleaning with a minimum of 4,000 psi and 4 gallon per minute using a rotating pencil nozzle, shall be used to clean and free all foreign material within the manhole. Detergent water and cleaning or muriatic acid shall be used when grease and oil are present. All materials resulting from the cleaning of manhole shall be removed prior to application of coating.

Active water infiltration shall be stopped by using a cementitious water plug or hydro-active grout such as Strong-Seal Strong Plug, Quadex Hydra-Plug or approved equal which is compatible with the specified coating. Prepared surfaces should be tested, after cleaning but prior to application of the coating, if a specific pH or moisture content of the concrete is required according to manufacturer's recommendations.

Product Handling and Rehabilitation Conditions: Protective coating materials are to be handled according to their material safety data sheets. Materials are to be kept dry, protected from weather and stored under cover.

Repair and under-coat materials must be accepted and approved by the protective coating manufacturer for compatibility with the specified liner and shall be used to fill voids, structurally reinforce and rebuild surfaces, etc., as determined necessary. The Engineer and/or Inspector shall determine type of manhole rehabilitation to be used according to the following:

**Condition.** The manhole is assured to be exhibiting severe structural fatigue and collapse is imminent. Conditions indicating this degree of deterioration would be distortion beyond 10 percent, severe corrosion (exposed reinforcing), or large section (greater than 30 percent) of the structure is missing. An approved structural liner followed by a compatible approved non-structural (sulfate resistant) protective liner shall be used to rehabilitate the manhole. A letter from the manufacturer will be submitted certifying the compatibility of the structural liner with the corrosion resistant protective coating.

**Liner Application:** Application procedure shall conform to the recommendations of the liner manufacturer, including materials handling, mixing, environmental controls during application, safety and equipment. The liner application equipment shall be specifically designed to accurately apply the specified liner material and shall be regularly maintained and in proper working order. The liner material must be applied by a Certified Applicator of the liner manufacturer. The liner shall be applied to minimum thickness or as specified according to the Owner's requirements and Manufacturer's recommendations. Temperature of the surface to be coated shall be maintained between 40° F and 120° F during application. Prior to and during application, care should be taken to avoid exposure of direct sunlight or other intense heat source to the structure being coated. Where varying surface temperatures exist, care should be taken to apply the liner when the temperature is falling versus rising (late afternoon into evening versus early morning into afternoon).

**Warranty:** Contractor shall warrant to the Owner all work against defect in materials and workmanship for a period of 2 years, unless otherwise noted, from the date of final acceptance of the project. Applicator shall, within a reasonable time after receipt of written notice thereof, repair defects in material or workmanship which may develop during said 2 year period and any damage to other work caused by such defects for the repairing of same, at their own expense and without cost to the Owner.

### 3.6. Cleaning Manholes and Mains

The sanitary sewer lines and structures that are to be rehabilitated shall be cleaned using mechanical, hydraulically propelled or high velocity sewer cleaning equipment. The cleaning process shall remove all grease, sand, silts, solids, debris, etc. from each sewer segment, including the manholes. Selection of cleaning equipment and method for cleaning shall be based on the condition of the sanitary sewer mains at the time work commences and will be subject to approval. All cleaning equipment and devices shall be operated by experienced personnel. Satisfactory precautions shall be taken to protect the sanitary sewer mains and manholes from damage that might be inflicted through the improper use of the cleaning process or equipment. Any damage done to a sewer by the Contractor shall be repaired by the Contractor at the Contractor's expense to satisfaction. Cleaning shall also include washing of the manhole wall by high pressure water jet.

During Construction the Contractor Shall: Keep the work and surrounding premises within work limits free of accumulations of dirt, dust, waste materials, debris and rubbish.

Keep dust generating areas wetted down.

Provide suitable containers for storage of waste materials, debris and rubbish until time of disposal.

Dispose of waste, debris and rubbish off site at legal disposal areas.

Remove and dispose of all excess or waste materials, debris and rubbish from the site, structures and all facilities at the end of working hours.

The Contractor, when instructed, will be required to demonstrate the performance capabilities of the cleaning equipment proposed for use. If the results obtained by the proposed sanitary sewer cleaning equipment are not satisfactory, the Contractor shall use different equipment or attachments, as required, to meet

specification. More than one type of equipment or attachments may be required at a location. When hydraulic or high velocity cleaning equipment is used, a suitable sand trap, weir, dam or suction shall be constructed in the downstream manhole in such a manner that all solids and debris are trapped for removal.

Whenever hydraulically-propelled cleaning tools which depend upon water pressure to provide their cleaning force, or any tool which retard the flow of water in the sanitary sewer lines are used, precautions shall be taken to insure that the water pressure created does not cause any damage or flooding to public or private property being served by the manhole section involved. Any damage of property, as a result of flooding, shall be the liability and responsibility of the Contractor. The flow of wastewater present in the sanitary sewer main shall be utilized to provide necessary fluid for hydraulic cleaning devices whenever possible. When additional quantities of water from fire hydrants are necessary to avoid delay in normal working procedures, the water shall be conserved and not used unnecessarily. No fire hydrant shall be obstructed or used when there is a fire in the area. The Contractor shall be responsible for obtaining the water meter and all related charges for the set-up, including the water usage bills from respective water purveyor agency. All expenses shall be considered incidental to the cleaning of the existing sanitary sewer mains.

Hydraulic Cleaning: Hydraulic propelled devices which require a head of water to operate must utilize a collapsible dam. The dam must be easily collapsible to prevent damage to the sewer, surrounding property, etc. When using hydraulically propelled devices, precautions shall be taken to insure that the water pressure created does not cause damage or flooding to public or private property. The Contractor shall not increase the hydraulic gradient of the sanitary sewers beyond the elevation that could cause overflow of sewage into area waterways or laterals. The flow of wastewater present in the sanitary sewer main shall be utilized to provide necessary fluid for hydraulic cleaning devices whenever possible.

High Velocity Cleaning: Cleaning equipment that uses a high velocity water jet for moving debris shall be capable of producing a minimum volume of 50 GPM with a pressure of 1,500 psi for the sanitary sewer line and 3,500 psi for the (manhole) structure at the pump. Any variations to this pumping rate must be approved, in advance. To prevent damage to older sewer mains and property, a pressure less than 1500 psi can be used. A working pressure gauge shall be used on the discharge of all high pressure water pumps. The Contractors shall use, in addition to conventional nozzles, a nozzle which directs the cleaning force to the bottom of the pipe for sewers 18-in. and larger. The Contractor shall operate the equipment so that the pressurized nozzle continues to move at all times. The pressurized nozzle shall be turned off or reduce anytime the hose is held or delayed in order to prevent damage to the line.

Mechanical Cleaning: Mechanical cleaning, in addition to normal cleaning when required, shall be with approved equipment and accessories driven by power winching devices. The Contractor shall submit the equipment manufacturer's operational manual and guidelines, which shall be followed strictly, unless modified. All equipment and devices shall be operated by experienced operators so that they do not damage the pipe in the process of cleaning. Buckets, scrappers, scooters, porcupines, kites, heavy duty brushes, metal pigs and other debris removing equipment and accessories shall be used as appropriate and necessary in the field, in conjunction with the approved power machines. The use of cleaning devices such as rods, metal pigs, kites, porcupines, root saws, snakes, scooters, sewer balls and other approved equipment, in conjunction with hand winching device, or gas, electric rod propelled devices, shall be considered normal cleaning equipment.

### 3.7. Jacking, Boring, or Tunneling Pipe

Jacking: Suitable pits or trenches shall be excavated for the purpose of jacking operations for placing end joints of the pipe. When trenches are cut in the side of embankment, such work shall be securely sheeted and braced. Jacking operations shall in no way interfere with the operation of railroads, streets, highways or other facilities and shall not weaken or damage such facilities. Barricades and lights shall be furnished as directed by the Engineer and/or Inspector to safeguard traffic and pedestrians.

The pipe to be jacked shall be set on guides to support the section of pipe being jacked and to direct it in the proper line and grade. Embankment material shall be excavated just ahead of the pipe and material removed through the pipe, and the pipe forced through the opening thus provided.

The excavation for the underside of the pipe, for at least  $\frac{1}{3}$  of the circumference of the pipe, shall conform to the contour and grade of the pipe. A clearance of not more than 2 inches may be provided for the upper half of the pipe.

The distance that the excavation shall extend beyond the end of the pipe shall depend on the character of the material, but it shall not exceed 2 feet in any case.

The pipe shall be jacked from downstream end. Permissible lateral or vertical variation in the final position of the pipe from line and grade will be as shown on the plans or as determined by the Engineer and/or Inspector.

Any pipe that cannot be repaired to its original condition or is damaged in jacking operations shall be removed and replaced at the Contractor's expense. Jacking pits shall be backfilled immediately upon completion of jacking operations.

Excavation for "Boring" pits and installation of shoring shall be as outlined under "Jacking." Boring operations may include a pilot hole which shall be bored the entire length of crossing and shall be used as a guide for the larger hole to be bored. Water or drilling fluid may be used to lubricate cuttings. Variation in line and grade shall apply as specified under "Jacking."

Tunneling: Tunneling may be used when the size of the proposed pipe would make the use of tunneling more satisfactory than "Jacking" or "Boring." The excavation for pits and the installation of shoring shall be as specified under "Jacking." The lining of the tunnel shall be of the material shown on the plans.

Access holes for grouting annular space shall be spaced a maximum of 10 feet.

Joints: Joints for pipe for "Jacking," "Boring," or "Tunneling," shall be as specified in these specifications, or as shown on the project plans or shop drawings as per pipe manufacturer's recommendation.

Grouting of Bores or Tunnels: Annular Space between casing pipe and limits of excavation (borehole) shall be pressure grouted, unless otherwise specified on the plans.

### 3.8. Concrete Encasement, Cradles, Saddles and Collars

Concrete Encasement. When concrete encasement is shown on the plans or when directed, the trench is to be excavated and fine graded to a depth conforming to the details and sections shown on the plans. The pipe is to be supported by pre-cast concrete blocks of the same strength as the concrete for encasement and securely tied down to prevent floatation. Encasement concrete is to be placed to a depth and width conforming to details and sections shown on the plans.

Concrete Cradles. When concrete cradles are shown on the plans or when directed, the trench is to be prepared and the pipe supported in the same manner as described in Concrete Cradles, of this Section. The cradle shall be constructed in accordance with details and sections shown on the plans. Strap/Tie Downs shall be No. 4 rebar diameter minimum or better as determined by the Water System Inspector.

Concrete Saddles. When shown on the plans or when directed, pipe to receive concrete saddle is to be backfilled in accordance with Section 3.D. of this specification to the spring line and concrete placed for a depth and width conforming to details and sections shown on the plans.

Concrete Collars. When shown on the plans or when directed, concrete collars are to be constructed in accordance with details and sections shown on the plans.

### 3.9. Adjust or Abandon Manholes

Existing manholes are to be adjusted or abandoned in accordance with Item 479, "Adjusting Manholes and Inlets", and as specified herein.

Manholes shall be lowered below street subgrade before placing base materials, and openings shall be protected by temporary hatch covers. Manholes adjusted in non-paved areas shall be set per proposed final grade.

Existing manhole rings and covers which are determined by the Inspector to be in an unacceptable condition, will be removed and replaced with new rings and covers. If the cone section is removed, the Contractor is to upgrade it to a 30 inch opening as required by 30 TAC § 217. All manhole openings upgraded to 30 inches shall then be considered Reconstruction of Manholes and subjected to all provisions contained under the appropriate section in this specification. Contractor shall take all necessary measures to prevent damage to existing or new rings, covers, or cones from equipment and materials used in, or taken through, the work area. If an existing or new manhole cover, ring, or cone is damaged by the Contractor, it shall be replaced (as directed by the Inspector) by the Contractor at his own expense. If concrete throat rings are to be installed, they must be used in conjunction with a UV stabilized polyethylene liner and I/I barrier. I/I barrier must meet the following ASTM standards: ASTM D790/1505 Density of Polyethylene Materials, ASTM D1238-10 Melt Flow Index, ASTM 638-10 Tensile Strength @ Yield (50mm/mm), ASTM 790 Flexural Modulus, ASTM 648 Heat Deflection Temperature @ IGEPAL, ASTM 1693-12 EsCR, 100% IGEPAL/10% IGEPAL.

Manholes shall be adjusted after the street's base material has been laid and before placing of the final surface course. Manholes that are going to be adjusted on an existing surface course (not planned for replacement) will be in accordance to the City of Converse standards, but must first be directed by the Engineer and/or Inspector. All manholes shall then be raised, or lowered a sufficient height so as to be level with the finished surface course. Adjustment in height will be made by the addition or removal of "throat rings" above the manhole cone, where feasible. A minimum of two and a maximum of six throat rings may be used at each adjusted manhole. All excess materials shall be disposed of by the Contractor at his own expense in an approved location.

The standard manhole ring and cover shall be ductile iron and manufactured to the dimensions shown in the plans. The ring and cover shall be hinged. Lifting slots cast into the covers shall be provided for lifting purposes. A water-resistant (cam lock) hinged cover shall be used in areas of minimal infiltration potential to allow venting. A watertight (bolt down) ring and covers must be used in areas of high infiltration potential, such as in the Edward's Aquifer Recharge Zone, an identified 100-year floodplain, or as otherwise directed by the Engineer and/or Inspector. The nominal cover diameter shall be 32 inches, with a 30 inch clear opening, as required by TCEQ. Rings shall have a minimum of four 1 inch holes/slots for anchoring purposes. Rings shall be a minimum of 4-1/2 inches in height or as otherwise accepted by the Engineer and/or Inspector. Slots for embedment/lightening are not allowed in ring flanges.

**Water-Resistant Rings and Covers:** Rings and covers shall have two hinges for added stability. The hinge shall have a drain to allow for proper debris and foreign object removal. Prior to acceptance of the work, a stainless steel keyed "cam" lock shall be provided by the Contractor to the Inspector. When the key is inserted in the cam, it shall remain in the lid while the cam is in the open (unlocked) position. When in the closed (locked) position, the key can be removed. When not in use, the cam lock key hole shall be covered with a plastic plug to prevent infiltration of debris. The cover shall positively lock at 90° to prevent accidental closure and open fully to 120°. The cover shall also include a single multi-tool lifting slot adjacent to the edge of the cover to facilitate opening/lifting/prying once it is unlocked. Covers shall be provided with a continuous vulcanized (one piece) EPDM gasket with a shore durometer of 70 ±5 permanently attached to the cover.

**Watertight Rings and Covers:** Rings and covers shall be the same as above for water-resistant version, except the covers shall be bolted to the ring instead of secured with the cam lock mechanism. No vent hole(s) shall be provided. A minimum of four 1/2 inch diameter, stainless steel, hex head bolts shall be provided for each cover. The 4 bolt holes in the covers shall be evenly spaced and provided with a minimum 1-1/2 inch diameter counter sink for the bolt heads. On the fastened and bolted position, the bolt heads shall not extend above the surface or the cover. Washers of a size and material as approved by the Engineer and/or Inspector shall be provided for the bolts to insure air and water tightness.

The finished ring and cover shall have the bearing surfaces machined ground and sets of rings and covers shall be marked in such a way that they can be matched for assembly in the field. All covers shall have the

words "Sanitary Sewer" cast thereon. Ring and cover shall have the approved foundry's name, part number, country of origin preceded by "Made in" (example: MADE IN USA) in compliance with the country of origin law of 1984, and production date (example: mm/dd/yy) for tracking purposes. Each casting must be marked with DI and ASTM A536 or A536 80-55-06 to verify the materials used. Castings without proper markings shall be rejected.

Material excavation from around the manholes shall be replaced with flowable fill in accordance with these specifications, and select materials from the excavation (as shown in the contract documents). All excess materials shall be disposed of by the Contractor at his own expense and in an approved location. The Contractor also has the option of backfilling with approved secondary materials, subject to the provisions in this specification.

Manholes existing on sewer lines replaced by new sewer piping and which are no longer needed for the revised sewer network are to be classified as "Abandon Manhole". Work required on an abandoned manhole is to consist of installing a permanent concrete plug on all pipes within the manhole, removing the top of the manhole to an elevation of 2-ft. below proposed subgrade or existing grade, whichever is the lower elevation, and backfilling the manhole with a grout material as specified. The ring and cover of the manholes are to be removed and delivered to the City of Converse's facility designated by the Engineer and/or Inspector. If directed, drainage holes are to be drilled in the bottom of manhole walls prior to backfilling.

### 3.10. Cut and Restore Pavement

Where sewers must be installed in streets or other paved areas that are going to remain, the work is required to be in accordance with Item 400, "Excavation and Backfill for Structures".

When allowed by the construction sequence shown on the plans or as directed, a "Temporary Concrete Cap" of the depth and class of concrete as shown on the plans or as directed may be used in lieu of a permanent repair.

### 3.11. Concrete Sidewalks, Driveways, Curbs, Medians and Islands Replacement

Existing concrete sidewalks, driveways, curbs, medians and islands required to be removed and replaced solely for sewer installation are to be a part of sewer work. Removal is to be in accordance with Item 104, "Removing Concrete". Replacement is to be in accordance with the plans and with Item 529, "Concrete Curb, Gutter and Combined Curb and Gutter", Item 530, "Intersections, Driveways and Turnouts", Item 531, "Sidewalks", and Item 536, "Concrete Medians and Directional Islands".

Any work done due to damage to curbs, sidewalks, driveways, islands or medians outside the limits shown on the plans or approved in advance will not be measured for payment but is to be restored at the Contractor's expense.

### 3.12. Removing and Replacing Chain-Link and/or Wire Fence

Existing chain link or wire fences required to be removed solely for sewer installation is to be replaced as part of the sewer work to a condition comparable to that at removal. The existing fence materials may be reused if they are not damaged during removal. Any removal or damage to existing fences outside the limits shown in the plans or not approved in advance will not be measured for payment but is to be restored at the Contractor's expense.

### 3.13. Abandon Sewer Lines

When shown on the plans, existing sewer lines, including any washouts and voids, are to be abandoned by injecting the line with a flowable cement based grout of at least 100 psi. The grout mix design and method of installation are to be approved prior to beginning operation.

Abandonment of sanitary sewer lines shall be accomplished by installing the grout material with sufficient pressure and in numerous locations. The method of installation shall be able to meet the requirement of completely filling the existing sanitary sewer line and any voids adjacent to the sanitary sewer line. The method shall adequately provide for the removal and legal disposal of existing sewer materials in the system. The method shall provide for the release of air. When intermediate points are required to be constructed for the abandonment of the system, they shall be a part of the abandonment project process.

Sanitary sewer pipes smaller than 15" in diameter are generally not required to be grouted, unless it is required by the plans. Pipes to be abandoned shall be grouted only if required by the plans and payment as per these specifications is provided.

### 3.14. Television Inspection

Immediately upon cleaning the sanitary sewers, all new sewer mains are to be televised and videotaped to determine the condition of the line and to locate service connections. The Engineer and/or Inspector and Contractor will observe the TV inspection in progress. The Contractor is to submit 1 copy of a color DVD of the recordings and logs of the televised inspection to the Engineer.

The Contractor shall not be allowed to float the camera. There may be occasions during the televised inspection of a manhole section when the camera will be unable to pass an obstruction. At that time, and prior to proceeding, the Contractor shall contact the Inspector. If the length of sewer line cannot be televised because of obstructions, the Contractor shall clean the system as is necessary. If, in the opinion of the Inspector, the obstruction is attributed to a collapsed main or pipe deflection, televising shall be suspended, payment shall be made based on the actual televised length, and the remaining televising of the sewer line shall be continued upon successful correction of the blockage by the Contractor at his expense. No additional payment shall be made for additional setups required due to obstructions encountered during televising.

The Contractor is solely responsible for any damage of sewer mains as a direct result of televising operations. Any repair shall also be the responsibility of the Contractor. The method(s) used for securing passage of the camera are at the discretion of the Contractor, as approved by City of Converse. No separate and/or additional payment will be made for any excavation, man entry, or any other method which may be required to retrieve video equipment that may have been hung up, destroyed, and/or lost during the operation.

Post-Construction Television Inspection. TV inspection is to be done 1 manhole (structure) section at a time. The flow in the section being televised shall be bypassed if the line is in service and the flow exceeds 25% of the internal pipe diameter. When the depth of flow at the upstream manhole of the manhole section being worked is above the maximum allowable for television inspection, the flow shall be reduced to allowable levels by temporarily plugging or blocking the flow or bypass pumping, as approved

Obstructions and Hindrances. All sections of the new sewer main are to be televised. Contractor is to insure the main is clean and clear of obstructions prior to performing televising activities. Any abnormalities such as, but not limited to, misaligned joints, cracked/defected pipe, rolled gaskets, shall be repaired by the contractor at his expense. Sections requiring repair shall be re-televised to verify condition of repair. No additional payment is to be made for additional set-ups required or delays due to repairs or removal of obstructions.

By-Pass Pumping. The Contractor shall perform bypass pumping operations in accordance with Specification.

The Contractor shall furnish all labor, supervision, tools, equipment, appliances, and materials to perform all operations in connection with bypass pumping of sewage flow for the purpose of preventing interference with the televising of the sanitary sewer manholes and mainlines as well as providing reliable sewer service to the occupants of the buildings being served.

The Contractor will be required to provide adequate pumping equipment and force mains in order to maintain reliable sanitary sewer service in all sanitary sewer lines involved in this project. The Contractor shall notify

the Inspector should a surcharge occur during the televising process which results in overflows of sewage. In case of bypass equipment failure, the Contractor shall discontinue work and release sewer flows until such time as equipment failure is corrected. The location of the pump(s), force main(s), and discharge points shall be approved by City of Converse. Under no circumstances shall the flow be interrupted or stopped, such that damage is done to either private or public property, or sewage flows or overflows into a storm sewer or natural waterway

The Contractor shall provide bypass pumping of sewage around each segment(s) of pipe that is to be televised and shall be responsible for all required bulkheads, pumps, equipment, piping, and other related appurtenances to accomplish the sequence of pumping. A qualified person shall man the pumps, on-site, at all times during the bypassing procedure

All piping, joints, and accessories shall be designed to withstand the maximum bypass system pressure, or a minimum of 50 psi, whichever is greater. During bypass pumping, no sewage shall be leaked, dumped, or spilled into or onto any area outside of the existing sanitary sewer system. When bypass pumping operations are complete, all piping shall be drained into the sanitary sewer prior to disassembly. The Contractor shall demonstrate that the pumping system is in good working order and can successfully handle flows during cleaning and televising operations, prior to commencing with the cleaning and televising of the system.

Video Equipment Operations. The Contractor is to be responsible for the TV inspection equipment having an accurate footage counter which displays on the monitor the distance of the camera from the centerline of the starting manhole. The camera height is to be adjusted such that the camera lens is always centered (1/2 ID or higher) in the pipe being televised. In no case will the television camera be pulled or propelled through the line at a speed greater than 40-ft. per minute.

Post Repair TV Inspection. Upon completion of any repairs required by the Inspector

Engineer and/or Inspector, the Contractor will re-televising the sewer and submit these DVDs to the Inspector. These DVDs are to be permanently labeled as described in Section 2.K. and are to be used as a portion of the acceptance criteria. This post repair-TV inspection is to be done to the satisfaction of the Engineer and/or Inspector, and is subject to the same acceptance criteria as the post construction-TV inspection DVDs. Post repair-TV inspection is to be provided at the Contractor's expense.

Negotiability of Sewers. The Engineer and/or Inspector makes no guarantee that all of the sanitary sewer mains proposed to be TV inspected are clear for the passage of a camera.

No separate or additional payment will be made for any excavation, man entry or any other method, which may be required to retrieve video equipment that has been hung up, destroyed or lost during the televising operation.

### 3.15. Reconstruct Manholes.

The reconstruction of existing manholes, all types and sizes, will include the replacement of manhole ring and covers, the replacing of existing cone, manhole section or sections required, regardless of the type shown on the plans, and as specified herein.

Manholes shall be raised or lowered by replacing the existing cone and manhole section or sections as required for installation to the finished surface course. All openings shall be protected by hatch covers or the necessary steel plates. The Contractor shall be required to backfill all manholes with an approved flowable fill (in accordance with all requirements of the right-of-way owner having jurisdiction over the project scope) up to 1 foot above the cone section. All excess materials (of any type) shall be disposed of by the Contractor at his own expense, and in an approved location. All openings will be protected by hatch covers or steel plates, as needed.

Reconstructed manholes will be cleaned of any debris as accepted by the City of Converse's Inspector. If a new manhole cover, ring, or reconstructed manhole is damaged by the Contractor, it will be replaced, as

directed by the City of Converse Inspector, by the Contractor, at his expense. All installed concrete throat rings must be used in conjunction with a UV stabilized polyethylene liner and I/I barrier. I/I barrier must meet the following ASTM standards: ASTM D790/1505 Density of Polyethylene Materials, ASTM D1238 Melt Flow index, ASTM 638 Tensile Strength @ Yield (50mm/mm), ASTM 790 Flexural Modulus, ASTM 648 Heat Deflection temperature @IGEPAL, ASTM 1693 EsCR, 100% IGEPAL/10% IGEPAL.

For reconstructed existing manholes, apply a combination of both products with the cementitious coating first, followed by the epoxy coating. Kerneos SewperCoat 2000 HR regular, applied at the required one inch thick application, is the only product approved which does not require a subsequent epoxy coating. Other approved materials are as follows:

Cementitious coating: With required one inch thick application.

- Permacast CR-5000;
- Strong - Seal MS-2C;
- Standard Cement Material Inc. Reliner;
- Quadex Aluminaliner;
- ConShield Biotech Armor.

Epoxy coating: With specified thickness application.

- Raven 405 Series High Build Epoxy Liner: Required thickness – 125 mils;
- Spray Wall polyurethane System: Required thickness – 125 mils;
- Caboline Plasite 4500: Required thickness – 125 mils.

Existing monolithic manholes will not be reconstructed but replaced.

### 3.16. Air Release Assembly

Air release valves and appurtenant items will be installed at the locations shown on the plans unless otherwise directed.

### 3.17. Anchorage and Blocking

Suitable reaction blocking or anchorage will be provided at all locations specified on the plans. Anchor blocks will be constructed solidly behind the fitting and symmetrical with the axis of resultant thrust except where this is not possible as in the case of gravity anchorage for vertical bends. Special ties and anchor fittings may be utilized in conjunction with blocking when shown on the plans or as directed.

Concrete blocking for mains will be a minimum of 3000 psi placed between solid ground and the fitting except as otherwise shown on the plans. The area of bearing in contact with solid ground will be that shown on the plans or as directed.

All thrust blocking placed in conjunction with mains and appurtenances constructed in Pressure Zones (formally known as Service Levels) 9 through 15 shall be in accordance with Standard Drawings DD-839 Series. In all cases, the design of thrust blocking shall be of sufficient size to withstand a soil pressure of 3000 psf, unless specified otherwise in the job plans or specifications. The maximum soil pressure value that will be allowed for the design of thrust blocking shall be 5000 psf. When soil pressure bearing values of 4000 psf or 5000 psf are recorded for design of thrust blocks, copies of soil tests made for determining the bearing value of the soil in question shall be submitted to the Engineering for verification.

The blocking shall be placed so that pipe and fitting joints will be accessible. Pipe polywrap shall be placed between the pipe or fitting and the concrete.

The reaction block on the unused branch of a fitting shall be poured separately from the block across the back of the fitting. If they are poured simultaneously, a rigid partition shall be placed between the blocks.

Valves 12 inches or larger in size shall be supported on a concrete pad extending vertically from 12 inches below the bottom of the valve to the lower quarter point of the hub and laterally from face to face of hubs and transversely from wall to wall of the trench.

Sand Backfilling of Cross Trenches and Open Holes. Air release valves, copper tubing, meter boxes, or other specials will be backfilled with pit run sand which is free from clay lumps, organic material and other deleterious substances, and will be thoroughly consolidated by saturating with water, unless otherwise directed. The use of mechanical tamping equipment for compaction of backfill will not be permitted at such locations. Disposal of surplus excavated material and placement of sand will be considered subsidiary to trenching and backfilling and will not be paid for directly.

3.18. Rehabilitation of Lines.

3.18.1. Special Construction Conditions. (Rehabilitation of Lines)

For Work activities impacted by the size and shape of the existing pipe, the Contractor is herein informed that the pipe is not exactly circular and a normal diameter has been approximated.

On lines designated for a combination of repair and other specified rehabilitation work, the repair shall be accomplished before the other rehabilitation work.

Due to the age of the sanitary sewer lines to be rehabilitated, location of sewer lines and manholes in public right-of-ways, and soil conditions may arise which have not been anticipated by the plans and specification. In such a case, the Contractor shall submit a proposed construction method to solve specific situations problems not covered by the plans and specifications for approval prior to proceeding with the proposed work.

If, the specified method of rehabilitation is not the most effective method available to obtain the desired results, the Engineer and/or Inspector reserves the right to propose an alternate method of rehabilitation.

Once work has begun at a specific location, the Contractor shall diligently pursue the work to be done until the rehabilitation is complete. The Contractor shall schedule work such that sewer rehabilitation at each site is complete before moving to another location. Should the work not progress on schedule, the Engineer and/or Inspector may direct the Contractor to dispatch additional crews or equipment to the jobsites. The time limit for completion of this work will be strictly enforced. Such direction, shall not be cause for additional payment to the Contractor and will not serve as the basis of a claim for acceleration.

3.18.2. General

All pipe to be used shall have a corrosion resistant inner surface. All pipes, joints, and fitting supplies shall conform, as a minimum, to the requirements of any and all applicable ASTM or AWWA standard specifications for such procedure. A certificate of "Compliance with Specifications" shall be furnished for all piping materials supplied.

The interior and exteriors surfaces of the pipe shall be free from pinholes, cracks, pits or delaminations detrimental to the intended use of the product. No pipe having apparent holes or openings which could permit the passage of water or gases through the pipe wall will be installed.

Any visible repairs to the pipe performed by the manufacturer prior to shipment to the job site shall be recorded on a pipe inventory log and submitted to the Engineer and/or Inspector. The log shall reference the repaired unit as per the manufacturer's pipe numbering system.

On-site repairs will not be allowed without approval. All repairs shall be accomplished as per the manufacturer's recommended procedures, and must be done by an approved manufacturer's certified repairman.

Repairs on the outside surfaces shall be allowed if the remaining thickness of the wall laminate is greater than 80 percent on minimum wall thickness.

Pipe shall be field connected with joints meeting the performance requirements, as a minimum, of any applicable ASTM or AWWA Standard Specifications for such products so as to maintain water tightness. Joint materials shall be chemically resistant to the fluids to be conveyed and gases generated by the sewer. Joint shall provide a Leak-proof seal when deflected as per the manufacturer's recommended maximum deflection or as per the applicable ASTM or AWWA Standard Specification and shall have a rating equivalent to the pipe itself.

Stiffening ribs or rings within the lining inner diameter will not be allowed. Pipe shall have a smooth inner lining.

The Contractor shall provide sufficient data from the pipe manufacturer to demonstrate that the pipe supplied provides a 50 year service life for the various loading conditions. This data shall be submitted as required.

A higher pipe stiffness will be acceptable if recommended by the manufacturer to meet the performance specifications in a particular situation.

The Engineer and/or Inspector shall have the right to modify or change the required liner thickness, depending upon the field conditions determined from the video tape. An analysis of design criteria and calculations for the liner thickness shall be provided for approval. Liner thickness may vary for the same size sewer depending upon field condition of the pipes and depths. Physical characteristics and properties of the felt tube shall also be submitted if required.

The CIPP liner thickness required shall be calculated using standard resin and the Design Criteria and Values tables in the above references standards. The thickness shall be rounded to the next highest multiple of 1/16-in. after adding an allowance of 5 percent to the design thickness for resin migration. Contractor shall also verify the table for correctness and must have any modifications approved. These calculations shall be based on the following physical condition of the existing pipe:

All pipes shall be considered fully deteriorated.

All pipes shall be subject to full soil load of 120 lb/cf, with applicable live load, and water table 5-ft. below the top of the ground.

All pipes should be considered to have a minimum of 2 percent ovality in the circumference.

The liner inside diameter shall be a minimum of 36-in. A minimum clearance of 5 percent of the liner pipe O.D. should be allowed between O.D. of the liner pipe and the I.D. of the existing pipe.

Any reduced clearance (less than 5 percent) between the O.D. of the liner and the I.D. of the existing pipe may be allowed if the Contractor submits, as required, a statement demonstrating that the liner pipe manufacturer recommends and certifies the sliplining installation procedures with less than 5 percent, and as approved. Such clearance shall not be less than 1-in. (all around the pipe) between the O.D. of the liner and the I.D. of the existing pipe.

Any flexible pipe used shall be Fiberglass Reinforced Plastic (FRP) slipliner pipe and shall have a minimum pipe stiffness (PS) requirement of 36 psi based on the short term Modulus of Elasticity, at 5 percent deflection when tested in accordance with the applicable ASTM or AWWA Standard Specifications.

The pipe shall be furnished in a maximum of 20-ft. lengths.

- 3.18.3. The thickness of the pipe wall at joint shall be designed to be safely capable of withstanding all loading conditions, including, but not limited to, insertion, grouting of annular space, external hydrostatic pressure above the pipe centerline and internal pressure rating. Equipment

The Contractor shall provide the Engineer and/or Inspector with satisfactory evidence, upon request, that the equipment to be used on the rehabilitation work is adequate, has functioned effectively on previous similar work, and any damage to sanitary sewer lines, appurtenances and surrounding property caused by the use of the equipment will be repaired or replaced by the Contractor at the Contractor's expense and to the satisfaction of the Engineer and/or Inspector.

- 3.18.4. Sewer Flow Control.

Flow through the sewer, as measured at the manhole, shall not exceed 30 percent of pipe diameter during any construction operations.

Flow depths above the maximum allowable requirements shall be reduced to within allowable limits by plugging or bypass pumping as required.

Wastewater flow shall be blocked with a pneumatic sewer plug inserted into the line upstream of the section being worked. The plug shall be so designed that all or any portion of flow can be released as required. The Contractor shall station an observer at the manhole immediately upstream of the plug during the entire period that the line is plugged to constantly watch for flooding and sewage backup of upstream lines. Full flow shall be restored by plug removal as soon as possible after work has been completed.

When flow in a sewer line is plugged or bypassed, sufficient precautions must be taken to protect the sewer lines from damage that might result from sewer surcharging. Precautions must be taken to insure that sewer flow control operations do not cause flooding or damage to public or private property served by the sewers involved.

Contractor shall release flow or install a bypass pump should surcharging result in sewage bypassing into a storm sewer through indirect or direct cross connections between adjacent sanitary and storm sewer.

No sewer main shall be plugged during Contractor non-working hours. A temporary tie-in shall be made between the end of the new and existing main. Plugs at manholes shall be removed to allow the flow of sewage until work is resumed.

- 3.18.5. By-Pass Pumping.

Where required, the Contractor shall furnish all labor, supervision, plant equipment, appliances and materials to perform all operations in connections with by-pass pumping of sewage for the purpose of preventing interference with the rehabilitation of the sanitary sewer system and providing reliable sewer service to the occupants of the buildings being served.

The Contractor shall notify the Engineer and/or Inspector and the property owners at least 72 hours in advance of work which will affect their business or residence sewer service. The Contractor shall coordinate with all property owners to ensure that no damage will be caused to their property during any and all sewer rehabilitation work.

- 3.18.6. Pre-Installations

Prior to commencement of field operations, the Contractor shall furnish, for approval, a detailed schedule of all planned operation sequences and any other procedures that may be necessary to complete the job. Additionally, all inner diameter dimensions and distances between existing manholes shall be verified by the Contractor prior to ordering and manufacturing rehabilitation materials.

- 3.18.7. Pumps and Force Mains

The Contractor shall have, on the project site, adequate pumps and force mains with backup systems, as specified in the Item "Sanitary Sewer (By-Pass Pumping)" shown herein, in order to maintain reliable sanitary sewer service in case of any emergency that may arise during the rehabilitation operations.

#### 3.18.8. Safety

The Contractor shall conduct all operations in strict accordance with all applicable federal, state and local safety codes and statues and shall be fully responsible and obligated to maintain procedures for the safety of all work, personnel and equipment involved in the work.

Particular attention is drawn to those safety requirements involving work on an elevated platform or entry into a confined space.

The Contractor is advised that sewage encountered may contain harmful viruses and bacteria any may be detrimental to the health of workers. Utmost care is urged to prevent contraction of potentially dangerous diseases. The existing line is known to contain quantities of hazardous gases and caution is advised.

The areas occupied by workmen shall be protected by the best available devices for the detection of oxygen depletion and lethal and combustible gases. Such devices shall be frequently tested to assure functional capability.

All safety measures, including but not limited to safety personnel, first aid equipment, ventilating equipment and safety equipment are considered the responsibility of the Contractor. No direct payment will be made for these measures.

No sewer main trenches, manhole excavation or any other opening will be left open during non-working hours without proper protection.

#### 3.18.9. Pre-Rehabilitation Cleaning

It shall be the responsibility of the Contractor to remove all loose debris which is located within the sewer pipe. Payment for this work will not be made for separately, but will be considered subsidiary to this item.

#### 3.18.10. Pre-Rehabilitation Inspection

Inspection of sewer pipe shall be performed by experienced personnel trained in locating breaks, obstacles and service connections by closed circuit television inspection. The interior of the pipe shall be carefully inspected to determine the location of any conditions which may prevent proper installation of the rehabilitation materials. A videotape and suitable log shall be kept for later reference by the Engineer and/or Inspector and the Contractor. Payment for this work will be made for under the Item "Sanitary Sewer (Television Inspection)", described herein.

#### 3.18.11. By-Passing Sewage

When required for acceptable completion of a rehabilitation task, the Contractor shall provide for sewage flow maintenance around the section or sections of pipe designated for rehabilitation. The bypass shall be made by plugging the line at an existing upstream manhole and pumping the flow into a downstream manhole or adjacent system. The pump and bypass lines shall be of adequate capacity and size to handle the flow. Payment for this work will be made under the Item "Sanitary Sewer – By-Pass Pumping".

#### 3.18.12. Line Obstructions

If inspection reveals an obstruction that cannot be removed by conventional sewer cleaning equipment, such as heavy solids, dropped joints, protruding service connections or collapsed pipe that will prevent completion of the rehabilitation process, a repair excavation shall be made by the Contractor to uncover and remove or repair the obstruction. Payment for this work will be made under the Item "Sanitary Sewer – Repair".

3.18.13. Sewer Service Line Reconnections

Service line reconnections will not be required as part of the rehabilitation of sanitary sewer lines. All existing laterals shall be connected to the new, adjacent sewer main.

3.18.14. Utilities

The Contractor shall contact the appropriate utility companies to locate the existing underground facilities at the job site 48 hours prior to the beginning of construction.

The Contractor shall accommodate site specific utility locations and construction constraints. It is the responsibility of the Contractor to locate, protect and work around existing utility conditions.

3.18.15. Contractor Mobilization Area.

The Contractor shall be solely responsible for providing all storage sites, access to the sites or temporary right-of-way which may be required for proper completion of work.

3.18.16. Wet Out

The Contractor shall designate a location where the tube will be impregnated ("wet out") with resin using distribution roller and vacuum to thoroughly saturate the tube felt fiber prior to installation. The Contractor shall allow the Engineer and/or Inspector to inspect the materials and wet out procedure. A catalyst system compatible with the resin and tube shall be used.

3.18.17. Insertion

The wet out tube shall be inserted through an existing manhole or other approved access by means of an inversion process and the application of a water column sufficient to fully extend it to the next designated manhole or termination point. The tube end shall initially be turned out and attached to a platform ring or standpipe. The inversion water column will be adjusted to be of sufficient height to cause the impregnated tube to invert from manhole to manhole and hold the tube tight against the existing pipe wall, produce dimples at side connections, and flared ends at the manholes. The Contractor shall not be allowed to pull the wet out in place unless the Contractor can prove that this method of installation does not result in tears or abrasion of the tube or uneven redistribution of the resin.

3.18.18. Curing

After the insertion is completed, the Contractor shall supply a suitable heat source and water recirculation system capable of delivering hot water uniformly throughout the section to effect a consistent cure of the resin. The curing temperature shall be that recommended by the resin or catalyst system manufacturer. The heat source shall be fitted with suitable monitors to gauge the temperature of the incoming and outgoing water supply. Another gauge shall be placed between the impregnated tube and the invert of the original pipe at the manholes to determine the temperature during the resin curing process. Initial cure shall be considered completed when the exposed portions of the CIPP appear to be hard and the remote temperature sensing device indicates the cure period to be of adequate duration as recommended by the resin or catalyst system manufacturer and modified for the inversion process.

3.18.19. Cool Down

The Contractor shall cool the hardened CIPP to a temperature below 100° F before relieving the water column. Cool water may be added to the water column while draining hot water from a small hole at the opposite end of the CIPP so that a constant water column height is maintained until cool down is completed. Care shall be taken in the release of the water column so that a vacuum will not be developed that could damage the newly installed CIPP.

## 3.18.20. Test Period

The finished CIPP shall be continuous over the entire length of an inversion run and be free, as commercially practical, of visual defects such as foreign inclusions, dry spots, pinholes and delamination. It shall also meet the leakage requirements and pressure tests as specified. During the test period, which is defined as 12 calendar months after acceptance of the work, any defect which will affect the integrity or strength of the CIPP shall be repaired at the Contractor's expenses in a manner approved.

## 3.18.21. Sealing at Manholes

The CIPP liner shall make a tight seal at the manhole opening with no annular gaps. Under all circumstances, a 1/2-in. diameter activated Oakum bank soaked in Scotchseal 5600, or approved equal, shall be applied all around for a seal, unless otherwise approved. All large annular space shall be sealed by using activated Oakum soaked in Scotchseal 5600, or approved equal, and later covered with a cementitious mortar. This procedure shall be completed before proceeding to the next manhole section. This work shall not be paid for separately, but will be considered subsidiary to this Item.

## 3.18.22. Installation

Insertion Pits. The Contractor shall provide all necessary pits to completely reline the sewers. The location of insertion pits shall be subject to approval. The number of insertion pits shall be minimized. Insertion pits and lateral reconnection pits, if required, shall be constructed to the minimum size necessary for insertion of sliplining pipe or reconnection of service laterals. All pits shall be constructed with properly applied vertical side support.

## 3.18.23. Pipe Stockpiling and Handling

Pipe and fittings shall be stockpiled in a safe manner at each Contractor staging area or pit location. The stockpiling shall be arranged to cause a minimum of interference to pedestrian and vehicular traffic. When handling sliplining pipe, the Contractor shall take all precautions necessary to avoid damage to the pipe.

Pipe with deep cuts, scratches or gouges shall be rejected and replaced. If the pipe is found to have developed an irregular shape that will not allow pipe joining or insertion without the use of outside forces to bring pipe to a round shape, it shall be rejected and replaced. An irregularly shaped pipe that would necessitate the use of undue force that could cause damage to the pipe or joints shall be rejected and replaced.

## 3.18.24. Liner Pipe Installation

The sliplining pipe installation shall be the responsibility of the Contractor. The Contractor shall adhere to the manufacturer's pipe installation procedures. Sliplining pipe grade shall be maintained parallel to the grade of the sewer being relined. As the work progresses, the interior of the pipe shall be cleared of all dirt and debris.

The Contractor shall make all necessary arrangements and provide all necessary equipment to maintain sewage flows at all times. A combination of flow diversion or By-Pass Pumping may be used to control the level of sewage flows during sliplining operations. It may be necessary to increase the weir height in the diversion box and discontinue flow diversion prior to sliplining operations to provide a level of flow conducive to sliplining. The Contractor will divert or reinstate flows only with approval.

## 3.18.25. Sliplining Pipe Insertion

Within the insertion pit, the top half of the exposed pipe is to be removed to the springline. The bottom half is to be left in place, where it shall serve as a cradle for the sliplining pipe. The sliplining pipe shall be pushed into the exiting pipe. A tapered guide may be attached to the leading pipe of each section to be installed to help pipe clear small obstructions. A push ring shall be used to distribute load as per the manufacturer's recommendations for installation of the sliplining pipe. For each section to be lined, insertion shall be one

continuous operation until the planned termination point is reached. Closure in the insertion pit after installation may be accomplished using a long bell closure kit or other methods as approved.

3.18.26. Manhole Replacement

In those places where the entrance pit is excavated at an existing manhole, the manhole shall be repaired or replaced with a new manhole conforming to the specifications on manhole construction and in accordance with Standard Details included in the plans. This work shall be paid under the Item "Sanitary Sewer (Manhole Rehabilitation)".

3.18.27. Manholes

After insertion and grouting the sliplining pipe shall be cut out at manholes as detailed. The method of cutting shall be as to leave a smooth, clean, straight edge. Where detailed or required, mild steel ties shall be provided as needed to tie the sliplining to the manhole benching. This work will not be paid for separately, but shall be subsidiary to this Item.

3.18.28. Pipe Grade

Pipe grade shall be maintained within the limits shown on the plans. The Contractor shall be responsible for and take all necessary precautions to ensure that no adverse pipe grades result nor collapses of the sliplining pipe occur during grouting operations.

3.18.29. Annular Space Grouting

If TV Inspection shows caverns above or around the deteriorated pipe, the Contractor shall take care not to cause the ground to collapse over the deteriorated pipe.

After rehabilitation is in place, the Contractor shall fill the caverns with grout to prevent any future settling or collapse of the existing ground grout mix and grouting pressure shall be as approved prior to placement. Payment for this work will not be made separately, but shall be considered subsidiary to this Item.

3.18.30. Testing

The Contractor shall provide to the Engineer and/or Inspector and the City of Converse a video tape showing the completed work. Such videotape shall be of a quality to permit close-up viewing of the restored taps and the liner. A TV camera with 360° articulating lens shall be utilized to produce such videotape. Similar videotape shall be provided, when requested, during the test period. This work shall be paid for under the Item "Sanitary Sewer (Television Inspection)".

Install liner pipe through the existing pipe, including line deflection and curves, and location of insertion pits,

Install grout in annular space between liner pipe and existing sewer pipe, including details on proposed grout to be mixed, and

Technical data on pipe including information on pipe materials, physical properties and dimensions.

3.19. Point Repairs

3.19.1. General

Locate and replace small lengths of one or more pipe sections where isolated line failure has occurred due to settlement, corrosion, crushing, or separation of joints.

The Inspector may identify potential locations for point repair, but the Contractor is responsible for verifying locations.

Determine the location of service line repairs by smoke testing the manhole section in which the failed pipe is located. The City of Converse Engineer and/or Inspector will authorize the Contractor to make point repairs based on results of smoke testing.

Smoke testing shall not be performed within 24 hours of a rainfall event or if ponded or standing water is present on the ground or in the drainage channels in the area planned for smoke testing.

Smoke testing shall be accomplished utilizing two minimum 1,750 CFM blowers designed specifically for smoke testing of sewers. Place blower on the upstream and downstream manhole of the line section to be tested. Place sandbags in the upstream and downstream manholes to isolate the section being tested and prevent the migration of smoke into sections not being tested. Utilize smoke bombs as necessary to ensure a continuous supply of smoke is provided for the entire duration of the test period.

Determine the location of point repairs by smoke testing or video inspection of the manhole section in which the failed pipe is located. The Inspector will authorize the Contractor to make additional point repairs.

The Inspector will authorize each point repair after failure points are located. Do not make point repairs without prior authorization of the Inspector. Perform point repairs only on those portions of service lines which are located in an easement or right-of-way; perform no repairs to service lines on private property.

Replace all identified damaged pipe for point repairs unless otherwise directed by the Inspector.

#### 3.19.1.1.

Typical Sequence of Point Repair:

Perform pre-installation video inspection, if required, to verify location of sewer main point repair locations. Perform service testing between manholes to verify location of service lateral point repair locations.

After the location of a point repair is determined, excavate the required length for the point repair.

Prior to replacing a damaged section(s) of pipe, determine condition of the existing line on both sides of the point repair by lamping the main at least 10 feet in each direction. Determine whether additional lengths of main (beyond "minimum length" criteria) need replacement. Report need for additional replacement to Inspector and obtain authorization before proceeding.

Remove the damaged section(s) pipe and replace with new pipe, shaping the bottom of the trench and placing the required pipe bedding so that the grade of the replaced pipe matches the grade of the existing main. Establish proper grade for the section(s) of pipe being replaced using methods acceptable to the Inspector.

Connect the new pipe to existing main using flexible adapters. If joints cannot be made watertight using flexible adapters, place waterstop gaskets on each joint and encase in a reinforced concrete collar. Reconnect affected service connections or stacks using fullbodied fittings. No field fabrication of fittings is allowed.

After completion of point repair, and prior to backfill, perform a smoke test to demonstrate satisfactory integrity of the repair, in the presence of the Inspector. Test as specified in this specification. Repair and retest sections that fail until repaired sections pass the test.

Encase exposed pipe in cement stabilized sand.

Backfill the excavation as specified in this specification.

Perform a post-installation video inspection as specified in Item No. 866, "Sewer Main Television Inspection." Point repairs that show offset joints, non-uniform grade, incorrect alignment, excessive deflection or similar conditions are considered defective work. Contractor shall replace pipe and bedding, as required, to correct defective work.

### 3.19.1.2. Abandonment of Point Repair

Notify the Inspector if a pipe is exposed by excavation and is found to be in good condition, not requiring a point repair. That point repair shall not be performed.

Notify the Inspector if the pre-installation video inspection reveals that no point repair is required. The point repair shall not be performed.

Backfill the excavation, replace pavement or sidewalk, and repair and seed or sod unpaved areas. No separate pay item.

### 3.19.1.3. Obstruction Removal

Remote Device: Remove obstructions identified on video of a sanitary sewer line segment which could cause a non-uniform liner pipe installation or obstruction of the liner during installation. Obtain authorization from the City of Converse Construction Inspector for obstruction removal with a remote device before proceeding.

Use a power-driven cutting device (robotic cutter) to remove protruding taps. Cut protruding taps so that protrusions are no greater than  $\frac{3}{4}$  inch. If a protruding tap cannot be removed by the cutting device, then a point repair may be performed. Obtain authorization from the City of Converse Construction Inspector before proceeding.

To remove other obstructions, use a remote device. Pull or drive the device from manhole to manhole up to a continuous length of 500 feet using a solid steel mandrel, porcupine, root saw, bucket, robotic cutter or similar device to remove the obstruction. Select a device that is adequately sized to remove the obstruction.

Use excavation as the method of obstruction removal when installation of the liner in the sanitary sewer is in progress. If during the liner insertion operation, a collapsed sewer, offset joint, or other obstruction is encountered which prevents or blocks the passage or insertion of the liner, notify the Inspector for authorization to excavate.

Excavate at the point where there is an obstruction. Use a trench safety system as required.

Break out the existing sanitary sewer pipe (carrier pipe) as directed by the City of Converse Construction Inspector. Remove only that amount of material which is causing the obstruction. Remove the minimum amount of carrier pipe.

Under such conditions, replacement of the carrier pipe is not required. Do not disturb the existing sewer bedding during excavation. However, if embedment is disturbed during the obstruction removal procedure, place cement-stabilized sand or crushed stone beneath the liner. No Separate pay item.

When the liner is completely in place, encase it with crushed stone or cement- stabilized sand.

### 3.19.2. By-Pass Pumping.

Install and operate bypass pumping equipment as required to maintain sewage flow and to prevent backup or overflow. Comply with "Bypass Pumping" section of this specification.

### 3.19.3. Pipe Bursting/Crushing Replacement.

#### 3.19.3.1. Pit Location

Location and number of insertion or launching pits will be chosen by the Contractor, and will typically be located near existing or proposed manholes, P.I.'s in the line, at logical breaks in the construction phasing, or at locations to comply with access or maintenance requirements.

Pits shall be placed and located to minimize the total number of pulls and maximize the length of pipe replaced per pull, within the constraints of maintaining service and access and other requirements. Use excavations at point repair locations for insertion pits where possible.

#### 3.19.3.2. Operations

The Contractor shall provide equipment, planning, and job execution necessary to accomplish the work in an efficient manner and consistent with the objectives of this specification, including preventing damage to existing infrastructure, maintaining pedestrian and vehicle access, and providing continual sewer service to customers.

Pipe shall be assembled and fused on the ground in sections equivalent to the length of the anticipated pull. During installation, all bending and loading the pipe shall be in conformance with manufacturer's recommendations and shall not damage the pipe.

Manholes shall be prepared so as to provide pipe installation at the lines and grades indicated in the contract documents. The invert in the manholes shall be removed as required to allow for pipe installation activities and to accommodate invert replacement. Manhole inverts shall be restored upon completion with 3,000 psi grout so as to establish a minimum 4 inch thick bottom on the manhole after shaping per the contract documents.

#### 3.19.3.3. Equipment

The Contractor shall utilize pipe bursting/crushing equipment with adequate pulling/pushing force to complete pulls in timely manner. The Contractor shall provide equipment on the pulling mechanism to verify the pulling/pushing force exerted on the pipe does not exceed the manufacturer's recommendation for allowable pulling force to prevent damage to the pipe. The pulling force may not exceed the following: 6 tons for 8.625-in. O.D.; 10 tons for 10.75-in. O.D.; 17 tons for 14-in. O.D.; 23 tons for 16-in. O.D.; 28 tons for 18-in. O.D. Allowable pulling force for all diameters shall be determined by the Contractor depending on the pipe size, wall thickness, manufacturer, field conditions, pull distance, manhole integrity, bearing capacity of soils, adjacent infrastructure, related equipment and cable strength, and related considerations.

#### 3.19.3.4. Equipment Configuration

Equipment shall be configured with adequate knives or other appropriate devices to minimize interruptions in the installation process due to obstruction removal and other problems. Pipe shall be secured to the pulling/pushing device in accordance with standard practice. The diameter of the pulling/pushing head shall be equal or slightly greater than the pipe O.D.

#### 3.19.3.5. Minimize Noise Impact

Equipment used to perform the work will be located away from buildings so as not to create noise impact. Provide silencers or other devices to reduce machine noise as required to meet requirements.

#### 3.19.3.6. Protection

The Contractor shall provide for the general safety of workers, pedestrians and traveling public throughout this project. Existing surface improvements and underground facilities and utilities shall also be protected. Damage caused by the Contractor shall be repaired at his own expense. Protection to be provided includes:

Provide barricades, warning lights and signs for excavations created by point repairs. Conform to requirements of TxDOT, the City of Converse, and of contract documents.

Protection of Manholes. The Contractor will install all pulleys, rollers, bumpers, alignment control devices and other equipment required to protect existing manholes, and to protect the pipe from damage during installation. Lubrication may be used as recommended by the manufacturer. Under no circumstances will the pipes be stressed beyond their elastic limit.

Do not allow sand, debris, or runoff to enter the sewer system.

Verify location of all underground utilities and facilities potentially impacted by rehabilitation related or other project activities and take necessary precautions to provide protection from damage. Damage caused by the Contractor shall be at his cost and responsibility.

Protect the new pipe and components during all phases of work, including hauling, installation, entry into the entry pit and prevention of scarring or gouging of the pipe or components.

#### 3.19.3.7. Sealing Liner in Manhole

Allow liner pipe to normalize to ambient temperatures as well as recover from imposed stretch before cutting to fit between manholes, sealing at manholes, and manhole invert shaping. Normalization usually takes at least 12 hours for polyethylene.

Cut liner so that it extends four inches into manhole. Make a smooth, vertical cut and slope area over top of exposed liner using non-shrink grout.

Seal the annular space between liner and sanitary sewer main at each manhole with a chemical seal and non-shrink grout. Place strips of oakum soaked in sealer (Scotchseal 5600 as manufactured by 3M Corporation, or approved equal) in a band to form an effective water-tight gasket in the annular space between liner and existing opening in manhole. Make width of the sealing band a minimum of eight inches or the thickness of the manhole wall, whichever is greater.

Finish seal with a non-shrink grout placed around annular space from inside manhole. Apply grout in a band not less than six inches wide.

Reshape and smooth the manhole invert. Form a smooth transition with a reshaped invert and a raised manhole bench to eliminate sharp edges of liner pipe, concrete bench, and channeled invert. Build up and smooth invert of manhole to match flow line of new liner.

#### 3.19.4. Sliplining.

##### 3.19.4.1. Obstruction Removal and Point Repair

Make point repairs and remove obstructions, such as roots, rocks and other debris, prior to installing liner pipe. Inspector is to first validate the need for either an obstruction removal or point repair. Refer to "Obstruction Removal" under "Point Repair" section of this specification.

##### 3.19.4.2. By-Pass Pumping

Install and operate bypass pumping equipment as required to maintain sewage flow and to prevent backup or overflow. Comply with "Bypass Pumping" section of this specification.

##### 3.19.4.3. Insertion or Access Pits.

Locate pits so that the total number is minimized and footage of liner pipe installed in a single pull is maximized. Where possible, use excavations at point repair locations for insertion pits.

Before excavating, check with various utility providers (e.g., CPS Energy, AT&T, Time Warner, etc.), and determine locations of utilities in or near the work area. Costs of utility repairs, temporary service and other

costs arising out of damage to, or interruption of, utilities, resulting from operations under this Contract, shall be borne by Contractor at no additional cost to City of Converse.

Perform excavation and backfill in accordance with this specification.

Perform excavation requiring trench safety in accordance with OSHA standards and this specification.

Install and operate necessary dewatering and surface water control measures.

#### 3.19.4.4. FRP Liner Pipe Installation

FRP Liner pipe may be pushed or pulled into existing sewers. Insert pipes, spigot end first, with bell end trailing. Apply pushing force to pipe wall end inside bell in accordance with manufacturer's instruction. Do not apply jacking loads to end of bell. Maximum allowable joint angular deflection one degree.

#### 3.19.4.5. Clamp Installation

Where excavations for liner pipe insertion are made between two manholes, cut ends of liner pipe smooth, square to pipe axis. Join liner pipes with appropriately sized stainless steel universal clamp couplings. Butt together gap between ends of liner pipe with space between ends not exceeding 2 inches.

Bedding in accordance with this specification.

#### 3.19.4.6. FRP Collar/Closure

Install FRP collar closure pieces in accordance with manufacturer's recommendations.

#### 3.19.4.7. Field Quality Control.

After liner installation, perform the following tests:

Service lateral connection test: After all service laterals have been completed for a particular sewer section, verify integrity of re-connections at points where they join liners and existing service lines by performing smoke test.

Refer to Item "Air and Deflection Testing for Sanitary Sewers," section for applicable test procedures.

#### 3.19.4.8. Sealing Liner in Manhole

Allow liner pipe to normalize to ambient temperatures and recover from imposed stretch before cutting to fit between manholes, sealing at manholes and shaping manhole invert. Allow at least 12 hours for normalization of polyethylene.

Cut liner so it extends 4-in. into manhole. Make smooth, vertical cuts and slope areas over top of exposed liner using non-shrink grout.

Seal annular spaces between liner and sanitary sewer main at each manhole with chemical seal and non-shrink grout. Place strips of oakum soaked in sealer in a band to form effective water-tight gasket in annular space between liner and existing pipes in manhole. Make width of the sealing band at least 12-in., or one-half pipe diameter, whichever is greater.

Finish seal liner pipe to host pipe with non-shrink grout placed around annular space from inside manhole. Apply grout in a band at least 6-in. wide. Obtain the City of Converse Engineer and/or Inspector's approval of sealing methods, including seal chemicals and materials.

Use cementitious grout to form smooth transitions with reshaped inverts and raised manhole benches to eliminate sharp edges of liner pipe, concrete benches, and channeled inverts. Build up and smooth manhole invert to match flow line of new liner.

3.19.4.9. Grouting Annular Space

Provide grouting plan and obtain approval of grouting plan from City of Converse Engineer and/or Inspector before proceeding with the Work.

Grout annular space between the outside of liner and inside of existing pipe for sewer pipe 18-in. in diameter and larger.

3.19.4.10. Post Installation Videotape Recording

Provide the City of Converse Engineer and/or Inspector with DVD showing completed work including condition of restored connections. Comply with requirements of "Television Inspection" of this specification.

3.19.4.11. Final Clean-up

Upon completion of installation and testing, clean and restore project area affected by work of this Section. No separate pay item.

3.20. Cleaning Manhole and Mains

3.20.1. Cleaning Manhole and Mains.

The Contractor shall be required to have all materials, equipment, and labor necessary to complete the cleaning of the sanitary sewer system on the jobsite prior to isolating it for the cleaning process. The Contractor shall only use the type of cleaning identified below to perform the necessary removal of all material which will not create hazards to health, property, affect downstream treatment plant processes, or damage to the sanitary sewer system.

The sanitary sewer mains, manholes, and structures shall be cleaned using mechanical, hydraulically-propelled, and/or high velocity sewer cleaning equipment. The cleaning process shall remove all debris, grease, sand, silts, solids, rags, rock, etc. from each sewer segment, including the manhole(s) or structures. Selection of cleaning equipment and the method for cleaning shall be based on the condition of the sanitary sewer lines at the time work commences and will be subject to City of Converse's pre-approval. All cleaning equipment and devices shall be operated by experienced personnel. Satisfactory precautions shall be taken to protect the sanitary sewer lines, manholes, or structures from damage that might be inflicted by the improper use of the cleaning process or equipment. Any damages done to a sewer line manhole, or structure by the Contractor shall be repaired by the Contractor at no additional cost and to the satisfaction of City of Converse. Cleaning shall also include the manhole or structure wall washing by a high pressure water jet.

3.20.2. Hydraulic Cleaning:

Hydraulic-propelled devices which require a head of water to operate must utilize a collapsible dam. The dam must be easily collapsible to prevent damage to the sewer line, property, etc. When using hydraulically-propelled devices, precautions shall be taken to insure that the water pressure created does not cause damage or flood public or private property. The Contractor shall not increase the hydraulic gradient of the sanitary sewers beyond the elevation that could cause overflow of sewage into area waterways or laterals. The flow of wastewater present in the sanitary sewer line shall be utilized to provide necessary fluid for hydraulic cleaning devices whenever possible.

3.20.3. High Velocity Cleaning:

Cleaning equipment that uses a high velocity water jet for removing all debris shall be capable of producing a minimum volume of 50 gpm, with a pressure of 1,500 psi, for the sanitary sewer main and 3,500 psi for the (manhole) structure at the pump. Any variations to this pumping rate must be pre-approved by the Inspector. To prevent damage to older sewer lines and property, a pressure less than 1,500 psi can be used. A working pressure gauge shall be used on the discharge of all high pressure water pumps. The Contractor shall use, in addition to conventional nozzles, a nozzle which directs the cleaning force to the bottom of the pipe for sewers 18" and larger in diameter. The Contractor shall operate the equipment so that the pressurized nozzle continues to move at all times. The pressurized nozzle shall be turned off or reduced anytime the hose is on hold or delayed in order to prevent damage to the line.

#### 3.20.4. Mechanical Cleaning:

Mechanical cleaning, in addition to normal cleaning when required, shall be with approved equipment and accessories driven by power winching devices. The Contractor shall submit the equipment manufacturer's operational manual and guidelines to the Inspector, which shall be followed strictly unless modified by the Inspector. All equipment and devices shall be operated by experienced operators so that they do not damage the pipe in the process of cleaning. Buckets, scrapers, scooters, porcupines, kites, heavy duty brushes, and other debris-removing equipment/accessories shall be used as appropriate and necessary in the field, in conjunction with the approved power machines. The use of cleaning devices such as rods, metal pigs, porcupines, root saws, snakes, scooters, sewer balls, kites, and other approved equipment, in conjunction with hand winching device, and/or gas, electric rod propelled devices, shall be considered normal cleaning equipment.

#### 3.20.5. General Requirements

In addition to the requirements specified herein, the Contractor shall maintain a clean work area and surrounding premises within the work limits so as to comply with Federal, State, and local environmental and anti-pollution laws, ordinances, codes, and regulations when cleaning and disposing of waste materials, debris, and rubbish. The Contractor shall also keep the work and surrounding premises within work limits free of accumulations of dirt, dust, waste materials, debris, and rubbish. Suitable containers for storage of waste materials, debris, and rubbish shall be provided until time of disposal. It is the sole responsibility of the Contractor to secure a licensed legal dump site for the disposal of this material. Under no circumstances shall sewage or solids removed from the main or manhole be dumped on the ground, streets, ditches, catch basins, storm drains, or sanitary sewers. Cost for this item shall be included in the price bid for sanitary sewer system cleaning.

The Contractor may be required to demonstrate the performance capabilities of the cleaning equipment proposed for use on the project. If the results obtained by the proposed sanitary sewer system cleaning equipment are not satisfactory to the Inspector, the Contractor shall use different equipment and/or attachments, as required, to meet the requirements of the contract documents. More than one type of equipment/attachments may be required at any given location within the project scope. When hydraulic or high velocity cleaning equipment is used, a suitable sand trap, weir, dam, or suction shall be constructed in the downstream manhole in such a manner that all the solids and debris are trapped for removal.

Whenever hydraulically-propelled cleaning tools which depend upon water pressure to provide their cleaning force, or any tool which retard the flow of water in the sanitary sewer mains are used, precautions shall be taken to insure that the water pressure created does not cause any damage or flooding to public or private property being served by the manhole section involved. Any damage of property, as a result of flooding, shall be the sole liability and responsibility of the Contractor. The flow of wastewater present in the sanitary sewer system shall be utilized to provide necessary fluid for hydraulic cleaning devices whenever possible. When additional quantities of water from fire hydrants are necessary to avoid delay in normal working procedures, the water shall be conserved and not used unnecessarily. No fire hydrant shall be obstructed or used when there is a fire in the area. The Contractor shall be responsible for obtaining the water meter and all related charges for the set-up, including the water usage bills from respective water purveyor agency. All expenses shall be considered incidental to the cleaning of the existing sanitary sewer system.

---

## 4. TESTING

### 4.1. Manhole Testing

The Contractor shall perform the testing for all sanitary sewer manholes in accordance with the following.

#### 4.1.1. Leakage Testing

All manholes must pass a leakage test. The Contractor shall test each manhole (after assembly and backfilling) for leakage, separate and independent of all other sanitary sewer piping, by means of either a hydrostatic test, vacuum test, or other methods approved by the Engineer and/or Inspector. The Contractor is hereby instructed to conduct either of the two identified tests in the following manner:

##### 4.1.1.1. Hydrostatic Testing

Hydrostatic testing shall be conducted by utilizing approved plugs to seal all influent and effluent pipes in the manhole and filling the manhole to the top of the cone with water. Additional water may be added over a 24-hour period to compensate for absorption and evaporation losses. At the conclusion of the 24-hour saturation period, the manhole shall be filled to the top and observed. Any measureable loss within a 30 minute period shall be considered an unsuccessful test and thus require the Contractor to assess the needed repairs, perform such repairs (subject to the approval of the Engineer and/or Inspector), and notify the Inspector when the retest will be performed. All effort, materials, or other costs shall be solely at the Contractor's expense.

##### 4.1.1.2. Vacuum Testing

General: Manholes shall be tested after construction/installation and backfilling with all connections (existing and/or proposed) in place. Drop connections and gas sealing connections shall be installed prior to testing.

Test Procedure: The lines entering the manhole shall be temporarily plugged with the plugs braced to prevent them from being drawn into the manhole. The plugs shall be installed in the lines beyond drop connections, gas sealing connections, etc. Prior to performing the test, the Contractor shall plug all lift holes and exterior joints with a non-shrink grout and plug all pipes entering the manhole. No grout shall be placed in horizontal joints prior to testing. Contractor shall use a minimum 60 inch/lb torque wrench to tighten the external clamps that secure the test cover to the top of the manhole. The test head shall be inflated in accordance with the manufacturer's recommendations. A vacuum of 10 inches of mercury shall be drawn, and the vacuum pump will be turned off. With the valve closed, the level vacuum shall be read after the required test time. If the drop in the level is less than 1 inch of mercury (final vacuum greater than 9 inches of mercury), the manhole will have passed the vacuum test. The required test time is 2 minutes.

Acceptance: Manholes will be accepted with relation to vacuum test requirements, if they meet the criteria above. Any manhole which fails the initial test must be repaired with a non-shrink grout or other suitable material based on the material of which the manhole is constructed. The manhole shall be retested as described above until a successful test is attained. After a successful test, the temporary plugs will be removed. To ensure that the plugs have been removed, Contractor shall only do so in the presence of the Inspector.

Repairs to Existing Manholes: Any existing manhole which fails to pass the vacuum test shall be closely examined by the Inspector and the Contractor to determine if the manhole can be repaired. Thereafter, the Contractor shall either repair or remove and replace the manhole as directed. The manhole shall then be retested and coated with a City of Converse-approved sewer coating as stated above. The Owner may elect to simply remove and replace the existing manhole with a new one. Any manhole excavated for repairs or excavated for tie in, shall be backfilled with flowable fill up to 1 foot below the top of the cone.

Measurement and Payment: Vacuum testing of new structures will not be a pay item. The cost of this work will be included in the bid price for the new manhole. Each vacuum test of an existing manhole shall be a separate pay item. Repairs to existing manholes shall be a separate pay item when authorized.

4.1.2. Holiday Testing

Inspect each sanitary sewer manhole using high-voltage holiday detection equipment. All detected holidays shall be marked and repaired by abrading the coating surface with grit disk paper, or other hand tooling method. After abrading and cleaning, additional protective coating material shall be applied to the repair area. All touch-up repair procedures shall follow the protective coating manufacturer's recommendations.

If a sanitary sewer manhole fails to pass one of the above tests, it shall be repaired in accordance with the manufacturer's recommendations and re-tested. It shall not be accepted until it passes all tests. All repairs and re-testing shall be at no additional cost to the City of Converse.

4.2. Low Pressure Air Testing.

The Contractor shall perform a low pressure air test, or an infiltration/exfiltration test, and a mandrel test before the installed work shall be considered accepted. If a gravity collection main is composed of flexible pipe, a deflection test will also be required. Flexible pipe is defined as pipe that will deflect at least 2% without structural distress. Contractor shall insure that all testing is performed in the presence of the Inspector, with copies of all written test results made available to the Inspector.

Materials for Air Testing. The Contractor is to furnish all materials and equipment for air testing including the Air Compressor.

Compressor Air Supply. Any source which will provide at least 300-cu. ft. per minute at 100 pounds per square inch.

The equipment for air testing will consist of valves, plugs, and pressure gauges used to control the rate at which air flows to the test section and to monitor the air pressure inside the plugs and, for large diameter pipe, joint testers as manufactured by Cherne Industrial, Inc., of Edina, Minn., or an approved equal. Test equipment is to be assembled as follows:

- Hose connection,
- Shut off valve,
- Throttle valve,
- Pressure reduction valve,
- Gage cock, and
- Monitoring pressure gage.

Figure 1

Air Testing Equipment Assembly Order

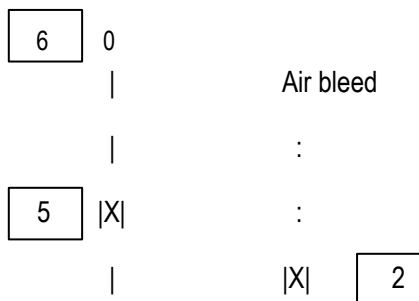

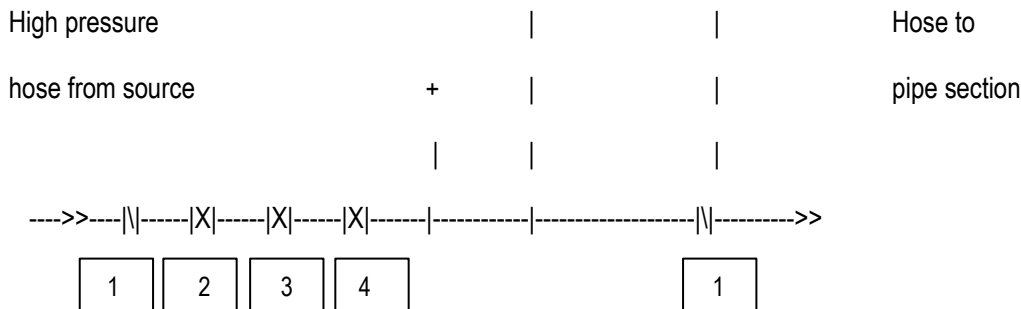

Test Procedures.

The procedure for the low pressure air test shall conform to the procedures described in ASTM C-828, ASTM C-924, ASTM F-1417 or other appropriate procedures, except for testing times. The test times shall be as outlined in this section. For sections of pipe less than 36-inch average inside diameter, the following procedure shall apply unless the pipe is to be joint tested. The pipe shall be pressurized to 3.5 psi greater than the pressure exerted by groundwater above the pipe. Once the pressure is stabilized, the minimum time allowable for the pressure to drop from 3.5 pounds per square inch gauge to 2.5 pounds per square inch gauge shall be computed from the following equation:

$$T = (0.085 \times D \times K) \div Q$$

T = Time for pressure to drop 1.0 pound per square inch gauge in seconds

K = 0.000419xDxL, but not less than 1.0

D = Average inside pipe diameter in inches

L = Length of line of same pipe size being tested, in feet

Q = Rate of loss, 0.0015 cubic feet per minute per square foot internal surface shall be used since a K value of less than 1.0 shall not be used.

There are minimum testing times for each pipe diameter as follows

Pipe Diameter Inches	Minimum Time Seconds/Ft	Length for Minimum Time Feet	Time for Longer Length Seconds/Ft
6	340	398	0.855
8	454	298	1.520
10	567	239	2.374
12	680	199	3.419
15	850	159	5.342
18	1,020	133	7.693
21	1,190	114	10.471

24	1,360	100	13.676
27	1,530	88	17.309
30	1,700	80	21.369
33	1,870	72	25.856

Note: Test time starts after the required 60 seconds of stabilization time.

The test may be stopped if no pressure loss has occurred during the first 25% of the calculated testing time. If any pressure loss or leakage has occurred during the first 25% of the testing period, then the test shall continue for the entire test duration as outlined above or until failure.

Mains with a 27 inch average inside diameter and larger must be air tested at each joint. If the joint test is used, a visual inspection of the joint shall be performed immediately after testing. The pipe is to be pressurized to 3.5 psi greater than the pressure exerted by groundwater above the pipe. Once the pressure has stabilized, the minimum time allowable for the pressure to drop from 3.5 pounds per square inch gauge to 2.5 pounds per square inch gauge shall be 10 seconds.

Mains that are greater than 33 inch diameter must be tested for leakage at each joint, or as approved by the Engineer and/or Inspector.

#### 4.3. Infiltration/Exfiltration Test

The total exfiltration, as determined by a hydrostatic head test, must not exceed 50 gallons per inch of diameter per mile of main per 24 hours, at a minimum test head of 2 feet above the crown of the main at an upstream manhole. The Contractor shall use an infiltration test in lieu of an exfiltration test when mains are installed below the ground water level. In such cases, the total exfiltration, as determined by a hydrostatic head test, must not exceed 50 gallons per inch diameter per mile of main 24 hours at a minimum test head of 2 feet above the crown of the main at an upstream manhole, or at least 2 feet above the existing groundwater level, whichever is greater. For construction work occurring within a 25-year floodplain, the infiltration or exfiltration must not exceed 10 gallons per inch diameter per mile of main per 24 hours at the same minimum test head as stated in the previous sentence. If the quantity of infiltration or exfiltration exceeds the maximum quantity specified, the Contractor shall propose to the Engineer, and receive approval therefrom, all necessary remedial action, solely at the Contractor's own cost, in order to reduce the infiltration or exfiltration to an amount within the limits specified herein.

#### 4.4. Deflection Testing

Deflection Testing: As stated in the 30 TAC § 217, deflection test shall be performed on all flexible pipe installed.

- For mains with inside diameters less than 27 inches, a rigid mandrel shall be used to measure deflection.
- For main with an inside diameter 27 inches and greater, a method approved by the Engineer shall be used to test for vertical deflections.

The deflection test must be accurate to within + 0.2% deflection. The test shall be conducted after the final backfill has been in place at least 30 days. No pipe shall exceed a deflection of five percent. If a pipe should fail to pass the deflection test, the problem shall be corrected and a second test shall be conducted after the failed area's final backfill has been in place an additional 30 days. The tests shall be performed without mechanical pulling devices. The Engineer and/or Inspector should recognize that this is a maximum deflection criterion for all pipes and a deflection test less than 5 % may be more appropriate for specific types and sizes of pipe. Upon completion of construction, the Engineer or other Texas Registered Professional Engineer appointed by the owner shall certify to the Inspector, that the entire installation has passed the deflection test. This certification may be made in conjunction with the notice of completion required in 30 TAC

§ 217.14. (1) of this title (relating to General Provisions). This certification shall be provided for the Owner to consider the requirements of the approval have been met.

#### Mandrel Sizing:

The rigid mandrel shall have an outside diameter (O.D.) not less than 95% of the inside diameter (I.D.) of the pipe. The inside diameter of the pipe, for the purpose of determining the outside diameter of the mandrel, shall be the average outside diameter minus two minimum wall thicknesses for O.D. controlled pipe and the average inside diameter for I.D. controlled pipe. All dimensions shall be per appropriate standard. Statistical or other "tolerance packages" shall not be considered in mandrel sizing.

#### Mandrel Design:

The rigid mandrel shall be constructed of a metal or a rigid plastic material that can withstand 200 psi without being deformed. The mandrel shall have nine or more "runners" or "legs" as long as the total number of legs is an odd number. The barrel section of the mandrel shall have a length of at least 75% of the inside diameter of the pipe. A proving ring shall be provided and used for each size mandrel in use.

#### Method Options:

Adjustable or flexible mandrels are prohibited. A television inspection is not a substitute for the deflection test.

### 4.5. Testing for Manhole Rehabilitation

Testing for manhole rehabilitation – structural and low sulfate, and structural lining and moderate sulfate shall consist of the following:

Visually verify the absence of leaks.

Perform an exfiltration test.

- For manholes 0 to 60-ft. deep, if water loss is 1-in. or less in five minutes, manhole passes the exfiltration test.
- For manholes over 6-ft. deep, if water loss is 1-in. or less plus 1/8-in. per additional foot of depth in five minutes, manhole passes the exfiltration test.

Perform a vacuum test on randomly selected manholes on every five manholes that are rehabilitated.

Testing for manhole rehabilitation – non-structural lining or high sulfate and structural lining high sulfate shall be tested as described above with the following additional requirement:

For every five manholes that are rehabilitated, one manhole shall be inspected using high-voltage holiday detection equipment. All detected holidays shall be marked and repaired by abrading the coating surface with grit disk paper or other hand tooling method. After abrading and cleaning, additional protective coating material shall be applied to the repair area. All touch-up procedures shall follow the protective coating manufacturer's recommendations.

If a manhole fails to pass on the above test, it shall be repaired in accordance with the manufacturer's recommendations and re-tested. It shall not be accepted until it passes all tests.

All repairs and re-testing shall be at no additional cost to the Owner. If more than 20 percent of the manholes fail to pass any testing requirement, all manholes shall be vacuum tested and holiday tested as appropriate at no additional cost to the Owner.

### 4.6. T.V. Camera Testing

After the vacuum tests on the manholes and the air tests on the sewer lines are performed by the Contractor, the Contractor shall perform T.V. Camera Testing. The T.V. test will be observed by City of Converse and Contractor personnel as the camera is run through the sewer lines.

Any sections in the sewer lines found by the camera such as broken pipe, misaligned pipe joints (that could result in a leak), etc. as determined to be damaged or abnormal are to be repaired or replaced by the Contractor at his expense.

#### 4.7. Sewer Force Main Flushing and Testing.

##### Flushing

Immediately upon completion of pipelaying, the Contractor will flush all mains which are scheduled to be tested. This flushing will be at the direction of the Engineer and/or Inspector and will consist of completely filling sections of main between valves and then displacing such initial volumes of water by introducing clear water from existing facilities into and through the main to the point of discharge from the main being flushed. The flow-through will continue until the Engineer and/or Inspector determines all dust, debris, or foreign matter that may have entered during pipe laying operations have been flushed out. The new line will then be left under system pressure for testing.

To avoid damage to pavement and inconvenience to the public, fire hoses will be used to direct flushing water from the main into suitable sewers.

##### Operation of Valves

No valve in the sanitary sewer force main system will be operated by the Contractor without prior permission. The Contractor will notify the Engineer and/or Inspector when a valve is to be operated and will only operate the valve in the presence of the Engineer and/or Inspector.

##### Hydrostatic Tests

All new mains will be hydrostatically field tested at a maximum test pressure of 200 psi before acceptance.

All joints which are found to leak either by observation or during any test will be made watertight by the Contractor. In case repairs are required, the hydrostatic field test will be repeated until the pipe installation conforms to the specified requirements and is acceptable. The expense for tests which meet specified requirements will be made in accordance with the unit price for the hydrostatic pressure test. No payment will be made for tests which fail to meet specified test leakage requirements.

After the new main has been laid and backfilled as specified, but prior to replacement of pavement, it will be filled with water for a minimum of 24 hours and then subjected to a hydrostatic pressure test. The specified test pressure will be supplied by means of a pump connected to the main in a satisfactory manner. The pump, pipe connection, and all necessary apparatus including gauges and meters will be furnished by the Contractor. Unless otherwise specified, the City of Converse will furnish potable water for filling lines and making tests through existing mains.

Before applying the specified test pressure, all air will be expelled from the main. To accomplish this, taps will be made, if necessary, at the points of highest elevation and afterwards tightly plugged. At intervals during the test, the entire route of the new main will be inspected to locate any leaks or breaks. If any are found, they will be stopped or repaired. The test will be repeated until satisfactory results are obtained.

The hydrostatic test will be made so that the maximum pressure at the lowest point does not exceed the specified test pressure. The duration of each pressure test will be a minimum of 4 hours for new mains in excess of 1,000-ft. after the main has been brought up to test pressure. The test pressure will be measured by means of a tested and properly calibrated pressure gauge acceptable. All pressure tests will be continued until the Engineer and/or Inspector is satisfied that the new main meets the requirements of these

specifications. Should any test of pipe in place disclose leakage greater than listed in the following Hydrostatic Test Leakage Allowances Table, the Contractor will, at his expense, locate and repair the defective joints until the leakage is within the specified allowance. Leakage is defined as the quantity of water supplied into the newly laid main, or any valved section of it, necessary to maintain the specified leakage test pressure after the main has been filled with water and the air expelled. The Contractor will notify the Engineer and/or Inspector prior to beginning the test, and the City of Converse's Inspector will be present during the pressure test.

**Hydrostatic Test Leakage Allowances Table  
(Maximum) @ 200 psi**

Nom Dia-Ty Pipe	Allowable Leakage in Gallons Per Hour (GPH) Pipe Length in Feet									
	100	200	400	600	800	1000	2000	3000	4000	5000
16"HDPE	0.34	0.68	1.36	2.04	2.72	3.40	6.80	10.20	13.60	17.00
20"HDPE	0.43	0.85	1.70	2.55	3.40	4.25	8.50	12.75	17.00	21.25

Note: Leakage allowances may be determined for footages not specifically listed by interpolation and/or by the combination of various tabular data.

Example No. 1: The maximum leakage allowances for 6,000 LF of 20" HDPE pipe would be the sum of the values for 5,000 LF and 1,000 LF, or 21.25 GPH plus 4.25 GPH equals 25.50 GPH.

Contractor's Personnel and Equipment. The Contractor will supply labor and equipment necessary to make all excavations required for flushing, equipment connections, and placing the mains in service.

Safeguarding and Backfilling Open Holes. The Contractor will be responsible for safeguarding any open holes excavated or left open for flushing and testing purposes. Following completion of testing, the Contractor will backfill such holes in accordance with appropriate provisions of Subarticle 3.(1), "Excavation and Backfill".

#### 4.8. Rehabilitation of Lines Testing

The Contractor shall provide to the Engineer and/or Inspector and the City of Converse a DVD showing the completed work. Such DVD shall be of a quality to permit close-up viewing of the restored taps and the liner. A TV camera with 360° articulating lens shall be utilized to produce DVD. Similar DVD shall be provided, when requested, during the test period. This work shall be paid for under the Item "Sanitary Sewer (Television Inspection)".

Quality Control.

Reference Standards

This specification references Insituform Technologies, Inc. (ITI) Standard Test Methods., which are made a part hereof by such reference, and shall be the latest editions and revisions thereof. ASTM F1216, "Standard Practice of Rehabilitation of Existing Pipelines and Conduits by the Inversion and Curing of a Resin Impregnated Tube", shall govern when this specification does not address installation methods and materials.

No change or alteration during the course of the contract shall be allowed without the prior written approval of the Engineer. Physical properties of the approved resin components of the materials, as well as the cured liner, shall conform with the minimum structural values as listed below:

Flexural Strength	4,500 psi	ASTM D-790
Modulus of Elasticity	250,000 psi	ASTM D-790

Certified copies of all test reports on the properties of the selected resin and (after placement) on the cured liner coupons performed by and for the Contractor shall be submitted. Results of additional product testing, normally performed for in-house quality control and process improvement, shall also be provided to the Engineer at no additional cost. The Contractor shall inform the Engineer, in writing, of the name and designation of all in-house quality control test and the sampling frequency of the tests on the resin and liner materials. The Engineer and/or Inspector shall also have the right to require the testing to be done at designated liner locations within the scope of the Contract. The Engineer and/or Inspector may also run test on random samples at no additional cost to the Contractor. Whenever possible, a short section of a sewer pipe very similar to the existing pipe may be placed in the manhole to run the liner under restrained conditions, for later testing and thickness measurements, at no additional payment. All samples shall be labeled before shipment for testing; and a duplicate piece shall also be provided, if requested, for inspection and testing by an independent laboratory, if required.

General Corrosion Requirements. The CIPP shall be fabricated from materials which when cured, will be chemically resistant to internal exposure to domestic sewage.

Water Analysis (Industrial Areas Only). In industrial areas where sewers are subject to possible organic and inorganic wastes other than normal domestic sewage, the Engineer and/or Inspector shall obtain samples of the dry weather sewage for chemical content analysis. This analysis shall be supplied to the Contractor for their information.

Submittals. The Contractor shall submit, along with the bid proposal, a copy of the recommended pipe installation procedures, certified by the pipe manufacturer.

#### 4.9. Pipe Bursting/Crushing Replacement Testing

After the existing sewer is completely replaced, internally inspect with television camera and DVD as required. The finished tape will be continuous over the entire length of the sewer between two manholes and to be free from visual defects.

Defects which may affect the integrity or strength of the pipe in the opinion of the Engineer and/or Inspector will be repaired or the pipe replaced at the Contractor's Expense.

The Contractor shall smoke test to verify all sewer service connections.

The following items are excerpted from TCEQ Chapter 317 requirements for gravity sewer construction testing (§317.a.4). Compliance with these requirements is required unless the Contractor obtains and provides written authorization from the TCEQ authorizing alternative testing and compliance procedures:

Testing of Installed Pipe. An infiltration, exfiltration or low-pressure air test shall be specified. Copies of all test results shall be made available to the executive director (TCEQ) upon request. Test shall conform to the following requirements:

Infiltration or Exfiltration Tests. The total exfiltration as determined by a hydrostatic head test, shall not exceed 50 gallons per inch diameter per mile of pipe per 24 hours at a minimum test head of 2-ft. above the crown of the pipe at the upstream manhole. When pipes are installed below the groundwater level an infiltration test shall be used in lieu of the exfiltration test. The total infiltration, as determined by a hydrostatic head test, shall not exceed 50 gallons per inch diameter per mile of pipe per 24 hours at a minimum test head of 2-ft. above the crown of the pipe at the upstream manhole, or at least 2-ft. above existing groundwater level, whichever is greater. For construction within the 25 year flood plain, the infiltration or exfiltration shall not exceed 10 gallons per inch diameter per mile of pipe per 24 hours at the same minimum test head. If the quantity of infiltration or exfiltration exceeds the maximum quantity of infiltration or exfiltration

exceeds the maximum quantity specified, remedial action shall be undertaken in order to reduce the infiltration or exfiltration to an amount within the limits specified.

Low Pressure Air Test. Perform in accordance with requirements of this specification.

Deflection Testing. Perform in accordance with requirements of this specification.

Clean-up and Restoration. Any damage to existing utilities, structures, storm drain systems, curbs, sprinkler systems, mail boxes, driveway, etc., shall be repaired as directed. All repairs and replacements shall be made at the Contractor's expense. Upon acceptance of the installation work and testing, the Contractor shall clean-up and restores the project area affected by operations. Daily clean-up of the project site to the satisfaction of the Engineer and/or Inspector shall also be required.

## 5. MEASUREMENT

### **Sewer Excavation and Non-stabilized Backfill**

Sewer excavation and non-stabilized backfill will be measured in accordance with Item 400, "Excavation and Backfill for Structures" but will not be measured for payment and will be considered subsidiary to the sewer line installation.

### **Trench Excavation Protection**

Trench excavation protection will be measured by the foot along the centerline of the trench where the depth exceeds 5-ft.

### **Sanitary Sewers**

Longitudinal measurement of sanitary sewers will be made along the centerline of the sewer from center of manhole to center of manhole or end of main by the foot of the various sizes and types (when a specific type is required) of sewers shown on the plans, in accordance with this specification, complete and accepted.

Plugging existing sewer lines will be considered subsidiary to the pipe installation.

### **Sanitary Sewer Cleanout**

One way cleanouts to be installed in all laterals at the customers property line and will be measured for payment by each installed.

### **Sanitary Sewer Laterals**

The lengths of laterals will be measured from the centerline of the sewer main to the connection at or within the customer's property line or premises. Wyes, tees, and bends of any kind will not be paid for separately for laterals but will be measured for payment by the foot of lateral to be installed.

### **Jack, Boring or Tunneling**

Jacking, Boring or Tunneling will be measured by the linear foot of bore or tunnel as measured from face to face of jacking pits.

Carrier pipe used in bores and tunnels or backed into place will be measured by the linear foot of pipe installed from end to end of pipe to the limits shown on the plans

Casing or liners, where required for plans of the size and material required will be measured by the linear foot actually installed in accordance with plans.

### **Vertical Stacks**

Vertical Stacks will be measured by the linear feet. Footage will be measured from the finish grade elevation (centerline) minus invert elevation minus 8 feet.

### **Manhole Structures**

Manholes structures will be measured by each manhole structure complete in place. Manhole structures will be installed where any pipe intercepted is larger than 24-inch in diameter. Rings and Watertight Covers, concrete ring encasement and I&I Barriers, will not be measured for payment, but will be considered subsidiary to the manhole.

### **Pre-Cast Manholes**

Manholes to 6 feet deep and designated on plan will be measured by each type manhole complete in place including those exceeding 6 feet in depth from the lowest invert elevation to the top of the ring. Rings and Watertight Covers, concrete ring encasement and I&I Barriers, will not be measured for payment, but will be considered subsidiary to the manhole.

Manholes deeper than 6 feet will be measured by the number of vertical feet in excess of 6 ft.

### **Adjusted or Abandoned Manholes**

Manholes adjusted or abandoned as prescribed herein, will be measured by each manhole. The excavation and backfill required and the I&I Barrier for Adjust Manholes will not be measured for payment, but will be considered subsidiary to this Item.

### **Select Backfill**

Cement Stabilized Backfill will be measured by the cubic yard in accordance with the backfill diagram shown on the plans or as directed.

### **Flowable Backfill**

Flowable Backfill will be measured by the cubic yard based on the dimensions and depths shown on the plans or as directed.

### **Select Bedding Material**

Where directed to be used for rigid pipe installations, Select Bedding Material will be measured by the cubic yard as dimensioned on the plans. Select Bedding Material is always required for Flexible Pipe installation; therefore, it will not be measured for payment.

### **Concrete Encasement, Cradles, Saddles and Collars**

Concrete encasement, cradles, saddles and collars for pipe will be measured by the cubic yard as dimensioned on the plans or as directed, complete in place. Reinforcing if required will not be measured.

### **Concrete Curb, Sidewalks, Driveways, Islands and Medians**

For concrete curbs, sidewalks, driveways, islands and medians required to be removed and replaced due to placement of sewer lines, removal of the existing concrete will be measured by the foot or by the square yard as dimensioned and detailed on the plans.

### **Cut and Restore Pavement**

The work to be done in the cutting and restoring of pavement will be measured by the square yard in accordance with the dimensions and details shown on the plans.

#### **Removing and Replacing Chain-Link and/or Wire Fence**

This work will be measured by the foot of fence removed and replaced, regardless of the type or height of the fence, complete in place. The existing fence materials may be reused unless, the existing materials were damaged during removal and should not be reused, the Contractor is to provide new material for the replacement work at his expense.

#### **Abandon Sewer Lines**

When shown on the plans, this work will be measured by linear foot complete in place.

#### **Television Inspection**

This Item will be measured by the foot of main televised for TV inspection. The foot measurement will be determined as the distance from the center of sewer manhole to the center of sewer manhole.

#### **Reconstruct Manholes**

Manholes completely reconstructed as prescribed herein, will be measured by the unit of each manhole (any type or size), regardless of the type shown on the plans.

#### **Automatic Air Release Valve**

Automatic Air Release Valve will be measured as each assembly of the size installed.

#### **Ductile-Iron Fittings**

Ductile-Iron Fittings will be measured by the weight to the nearest one-hundredth of a ton of the various sizes installed.

#### **Hydrostatic Pressure Test**

Hydrostatic Pressure Test will be measured as each successful test conducted on sanitary sewer force mains only. Hydrostatic testing of manholes will not be measured for payment

#### **Rehabilitation of Lines**

This Item shall be measured by the foot, based on the measured distance of existing sanitary sewer line to be rehabilitated from centerline of manhole to centerline of manhole.

#### **Point Repair**

This Item will be measured on an each basis. The minimum length of pipe to be replaced at each repair locations shall be 9-ft. Measurement for sewer line extra length point repair is on a linear foot basis in excess of minimum replacement length.

#### **By-Pass Pumping**

This Item will be measured by the "Lump Sum" as the work progresses. No additional measurement or payment will be made for conditions caused by the Contractor during construction.

#### **Rehabilitation of Manholes**

This Item will be measured by the vertical foot.

### **Cleaning Manhole and Mains**

Sanitary sewer manhole and mainline cleaning will not be measured for payment and shall be subsidiary to rehabilitation of manholes and lines.

### **Sliplining.**

Measurement for Sliplining is on a by foot basis for installed liner pipe, measure from center line of upstream manhole to center line of downstream manhole. Depth range for payment is based on depth measured at sewer main from natural ground level to flow line of sanitary sewer for each pipeline segment.

## **6. PAYMENT**

**Sewer Excavation.** Payment for sewer excavation and non-stabilized backfilling in accordance with these specifications will not be paid for directly but will be included in the unit price bid for the sanitary sewer pipe installation. Select bedding and stabilized backfill will be paid for under their own items of work.

**Trench Excavation Protection.** Payment will be made at the unit price bid for "Sanitary Sewer (Trench Excavation Protection)" in place. This price shall be full compensation for all labor, equipment, materials, tools, all components of the trench protection system which can include but not limited to sloping, sheeting, trench boxes or trench shields, sheet piling, cribbing, bracing, shoring, dewatering/diversion of water to provide adequate/acceptable drainage, any additional excavation or backfill required, jacking, jack removal, removal of the trench support after completion and all other labor, materials, tools, equipment and incidentals necessary to complete the work.

**Sanitary Sewers.** Payment will be made at the unit price bid shall be full compensation for all labor, equipment, materials, tools, and incidentals for "Sanitary Sewers" of the size, and type (when a specific type is required) specified on the plans complete in place.

Sanitary sewer force mains will be paid for at the unit price bid shall be full compensation for all labor, equipment, materials, tools, and incidentals for "Sanitary Sewers (Force Main)" of the size and type specified on the plans, complete in place.

Sanitary sewer service connections will be paid for at the unit price bid which shall be full compensation for all labor, equipment, materials, tools, and incidentals for "Sanitary Sewers Lateral Pipe)" of the size specified per linear foot complete in place.

**Sanitary Sewer Laterals.** Payment will be made at the unit price bid shall be full compensation for all labor, equipment, materials, tools, and incidentals for "Sanitary Sewer Lateral" of the size and type (when a specific type is required) specified on the plans per linear foot complete in place.

**Jacking, Boring or Tunneling.** Jacking, Boring or Tunneling will be paid for at the contract unit price bid per linear foot of jacking, boring or tunneling, which price shall be full compensation for furnishing all materials (except carrier pipe, casings or liners), labor, tools, equipment and incidentals necessary to complete the work, including excavation, grouting, backfilling, restoration to original ground conditions, and disposal of surplus materials.

Carrier pipe shall be paid for at the contract unit price bid which shall be full compensation for "Carrier Pipe for Jacking, Boring or Tunneling" per linear foot of pipe installed and measured as prescribed above.

Casings or liners shall be paid for at the contract unit price bid which shall be full compensation for "Casing or Liner" per linear foot of casing or liner installed and measured as prescribed above.

**Vertical Stacks.** Payment will be made at the unit price bid per linear foot which shall be full compensation for all labor, equipment, materials, tools, and incidentals complete in place.

**Sanitary Sewer Cleanouts.** Payment will be made at the unit bid price for "Sanitary Sewer Cleanout" of the size and type (when a specific type is required) specified on the plans which shall be full compensation for all labor, equipment, materials, tools, and incidentals complete in place.

**Manhole Structures.** Payment for Manholes structures, including the stack, rings, watertight covers, steps and concrete ring encasement, I&I Barriers, will be made at the unit price bid for "Sanitary Sewer Manhole Structure (Complete) of the type specified which shall be full compensation for all labor, equipment, materials, tools, and incidentals.

**Pre-Cast Manholes.** Payment for Pre-Cast manholes, including the stack, rings, watertight covers, steps and concrete ring encasement, I&I Barriers, will be made at the unit price bid for "Sanitary Sewer Pre-Cast Manhole (Complete)" of the type specified which shall be full compensation for all labor, equipment, materials, tools, and incidentals.

Payment for Extra depth manholes will be made at the unit price bid per linear foot as measured.

**Abandon or Adjust Manholes.** Manholes abandoned or adjusted will be paid for at the unit price bid for "Sanitary Sewer (Abandon Manhole)" or "Sanitary Sewer (Adjust Manhole)" which shall be full compensation for all labor, equipment, materials, tools, and incidentals to complete the work.

#### **Select Backfill.**

**Cement Stabilized Backfill.** Payment will be made for "Cement Stabilized Backfill" at the unit price bid for "Sanitary Sewer (Cement Stabilized Backfill)" which shall be full compensation for all labor, equipment, materials, tools, and incidentals to complete the work.

**Flowable Backfill.** Payment for "Flowable Backfill" will be made at the unit price bid for "Sanitary Sewer (Flowable Backfill)" which shall be full compensation for all labor, equipment, materials, tools, and incidentals to complete the work.

**Select Bedding Material.** Payment for "Select Bedding Material" for rigid pipe installations will be made at the unit price bid for "Sanitary Sewer (Select Bedding)". The select bedding for flexible pipes will not be paid for directly but will be subsidiary to the flexible pipe.

**Concrete Encasement, Cradles, Saddles and Collars.** Payment will be made at the unit price bid for "Sanitary Sewers (Concrete Encasement, Concrete Cradles, Concrete Saddles and Concrete Collars)" which shall be full compensation for all labor, equipment, materials, tools, and incidentals to complete the work.

**Concrete Curbs, Driveways, Sidewalks, Islands or Medians.** Payment for replacement of curbs, driveways, sidewalks, islands and medians will be made at the unit price bid for "Sanitary Sewers (Concrete Sidewalk)", "Sanitary Sewers (Concrete Driveway)", "Sanitary Sewers (Concrete Islands)", "Sanitary Sewers (Concrete Medians)" and "Sanitary Sewer (Concrete Curb)" which shall be full compensation for all labor, equipment, materials, tools, and incidentals to complete the work.

**Cut and Restore Pavement.** Payment will be made at the unit price bid for "Sanitary Sewers (Cut and Restore Pavement)" which shall be full compensation for all labor, equipment, materials, tools, and incidentals to complete the work.

**Remove and Replace Chain-Link and/or Wire Fence.** Payment will be made at the unit price bid for "Sanitary Sewer (Remove and Replace Fence)" which shall be full compensation for all labor, equipment, materials, tools, and incidentals to complete the work.

**Abandon Sewer Lines.** Payment will be made at the unit price bid for "Sanitary Sewer (Abandon Pipe)" of the size shown on the plans which shall be full compensation for all labor, equipment, materials, tools, and incidentals to complete the work.

**Television Inspection.** The work performed and materials furnished in accordance with this Item and measured as provided under "Measurement" will be paid for at the unit price bid for "Sanitary Sewer (Television Inspection)." This price shall be full compensation all labor, materials, equipment, tools, logging, and all incidentals necessary to complete the work.

Testing Sanitary Sewers for leakage, including all labor, materials, and equipment necessary to perform the tests, will not be paid for directly but will be considered incidental to the various Sanitary Sewer pay items.

**Reconstruct Manholes.** Payment for reconstructed manholes, complete in place will be made at the unit price bid for "Sanitary Sewer (Reconstruct Manhole)" which shall be full compensation for all labor, equipment, materials, tools, and incidentals to complete the work.

**Automatic Air Release Valve.** Payment for "Automatic Air Release Valve" will be made at the unit price bid for "Sanitary Sewer (Automatic Air Release Valve) (Complete)" and will be full compensation for each assembly of the various sizes installed in accordance with the details shown on the plans. This payment will also include selected embedment material, anti-corrosion embedment when specified, blocking and various sizes and types of meter boxes.

**Ductile-Iron Fittings.** Payment for "Ductile-Iron Fittings" will be made at the unit price bid for "Sanitary Sewer (Ductile-Iron Fittings)" and will be full compensation for each ton of fittings of all sizes and types installed and will be based upon the weights of fittings shown in the "Weights of Ductile-Iron and Cast-Iron Fittings" table.

**Hydrostatic Pressure Test.** Payment made for "Hydrostatic Pressure Test" will be made at the unit price bid for "Sanitary Sewer (Hydrostatic Pressure Test)" and will be full compensation for each successful test conducted on sanitary sewer force mains only. No direct payment will be made for hydrostatic testing manholes.

No direct payment will be made for concrete blocking of sanitary sewer force mains; furnishing and installing the joint restraint system; coating and wrapping pipe joints; polyethylene wrapping; trench excavation below specified limits; excavation and removal of unsuitable material at bottom of trench grade and restoration with approved material; supporting pipe or conduits of public utilities; and flushing sanitary sewer force mains. This work will be considered subsidiary to the various bid items.

**Rehabilitation of Lines.** The work performed and materials furnished in accordance with this Item and measured as provided under "Measurement", will be paid for at the unit price for "Sanitary Sewer (Line Rehabilitation)". This price shall be full compensation for all labor, equipment, materials, tools, pre-rehabilitation line cleaning, water, clean-up, dump sites and hauling of debris, labor, materials and equipment used in replacing bases and pavements, access to right-of-ways and easements as necessary, removal of equipment due to bad ground or poor pipe conditions, and other incidentals necessary to complete the work for either method of sanitary sewer line rehabilitation.

**Point Repair.** The work performed and materials furnished in accordance with this Item and measured under "Measurement" will be paid for at the unit price bid for "Sanitary Sewer (Point Repair)", for sizes and types constructed (when a specific type is required), regardless of depth. This price shall include all materials, including pipe, trenching, pumping, shoring and bracing, sand cushion, concrete plugs, laying and jointing, backfilling, tapping, water, labor, tools, equipment, pavement work and all incidentals necessary to complete the work.

Payment for sewer line extra length will be in accordance with this Item and measured under "Measurement" will be paid for at the unit price bid for "Sanitary Sewer (Point Repair sewer line extra length)", for sizes and types constructed (when a specific type is required), regardless of depth. This price shall include all materials, including pipe, trenching, pumping, shoring and bracing, sand cushion, concrete plugs, laying and

jointing, backfilling, tapping, water, labor, tools, equipment, pavement work and all incidentals necessary to complete the work.

**By-Pass Pumping.** The work performed and material furnished in accordance with this Item and measured as provided under "Measurement" will be paid for the unit price bid for "Sanitary Sewer (By-Pass Pumping)". Partial payments of this "Lump Sum" bid will be as follows:

When initial set-up and operation of the bypass system begins, 40% of the line item will be paid.

The remaining portion of the line item will be paid when the bypass pumping operations for the entire job are completed.

**Rehabilitation of Manholes.** The work performed and materials furnished in accordance with this Item and measured as provided under "Measurement", will be paid for at the unit price bid for "Sanitary Sewer (Manhole Rehabilitation)". This price shall be full compensation for materials, labor, equipment, tools, testing and all incidentals necessary to complete the work.

**Cleaning Manholes and Mains.** All work described by this Item shall be subsidiary rehabilitation of manholes and lines

**Pipe Bursting/Crushing Replacement.**

The inserted pipe will be paid for per foot of pipe installed using pipe-bursting/crushing method for the pipe diameter, type, quantity, and depth specified and shall be full compensation for all labor, equipment, materials, tools, incidentals, all pipe installation materials, all submittals, sealing materials at manholes and annulus (if required), launching pits, receiving pits, post testing, shoring, bedding, backfill, and all necessary, corresponding, and related work specified herein.

Services. Locating and reconstruction of services and all connections of services will be paid for per each connection made, which shall be full compensation for all labor, equipment, materials, tools, and incidentals to complete the work, including fittings and pipe. Payment for abandoned services will be on as per each connection made basis.

Point Repairs. Point repairs will be paid for on as per each basis, as needed which shall be full compensation for all labor, equipment, materials, tools, and incidentals to complete the work... Extra length point repair will be paid based on the length of pipe replaced per repair beyond the length established for each single point repair item, as needed. Abandoned point repairs will be paid on a cubic yard basis, as needed.

Obstruction Removal. Obstruction removal will be paid for on as per each basis, as needed which shall be full compensation for all labor, equipment, materials, tools, and incidentals to complete the work.

Storm Water Pollution Prevention and Erosion Control Plan. Payment for this item will be based on the items and quantities of control measures included in the proposal on the basis indicated in the respective specification sections.

Site Restoration. Except as associated with point repairs and obstruction removals, site restoration for all impacts to surface improvements will be on a foot basis of the rehabilitated line segment. For point repairs and obstruction removals, site repair will be on as per each basis.

Television Inspection. Payment will be made for television inspection of the sewer line prior to pipe rehabilitation in accordance with this specification. There will be no additional or separate payment for "post-TV" video inspection, documentation, required submittals, and associated or related work.

By-Pass Pumping. The cost of any necessary by-pass pumping will be considered subsidiary to the appropriate pay items for pipe installation, television inspection, repair, or related work and will not be a separate pay item.

**Sliplining.**

Payment will be made at the unit price bid shall be full compensation for all labor, equipment, materials, tools, and incidentals for "Sliplining" of the size and type (when a specific type is required) specified on the plans per linear foot complete in place.

Insertion pits, access pits, clamp installation, embedment (bedding, haunching and initial backfill), field quality control (testing), sealing liner at manholes, grouting annular space, building up, shaping and reworking manhole inverts and benches, and pre-installation and post-installation cleaning and television inspection of completed work are included in sliplining unit price and not paid for separately.

Excavations initially begun as obstruction removals or point repairs which the Contractor later decides to use as insertion pits are considered as insertion pits and not paid for separately.

Trench safety systems, well pointing and other applicable bid items associated with insertion pits will be paid for at their respective contract unit prices.

DATE: 6/18/2026 11:51:57 AM  
 FILE: I:\024793 West Lucas Road Design\_Revision\Design Data\4 - Design\Plan Set\14\_Force Main\Lucas\_FM\_PP07\_REV2.dgn

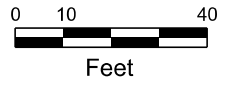
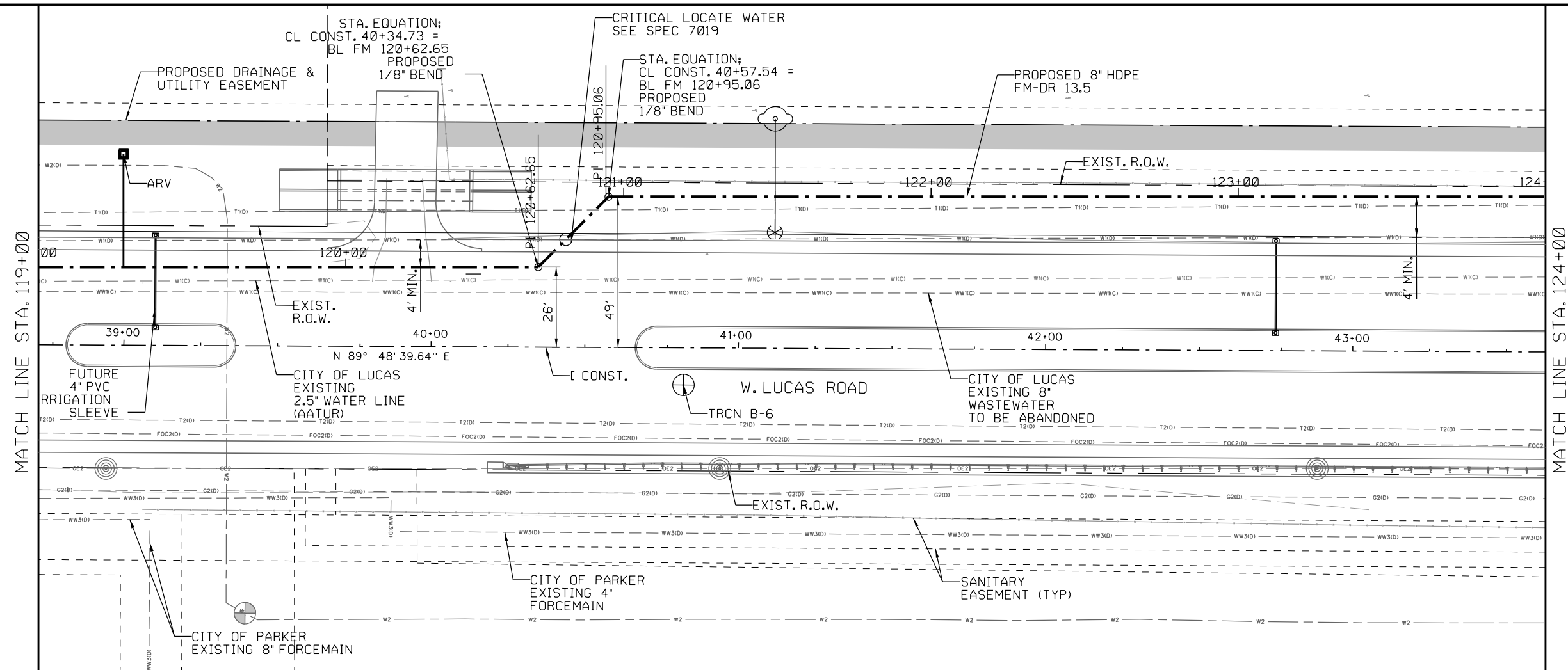

- NOTES:
1. HDPE PIPE TO BE HEAT FUSED CONFORMING TO ASTM D 2657.
  2. CONTRACTOR SHALL PROTECT AND SUPPORT ALL EXISTING UTILITIES AT CROSSINGS WITH THE FORCE MAIN.
  3. CULVERT K2 NOT SHOWN FOR CLARITY.
  4. OVERHEAD ELECTRIC AND POLES NOT SHOWN FOR CLARITY.
  5. THE CONTRACTOR SHALL PERFORM CRITICAL LOCATES TO DETERMINE THE DEPTH AND LOCATION OF UTILITIES PRIOR TO ANY EXCAVATION OR CONSTRUCTION ACTIVITIES.
  6. UNLESS OTHERWISE NOTED DEPTH OF ALL EXISTING UNDERGROUND UTILITIES ARE APPROXIMATE.

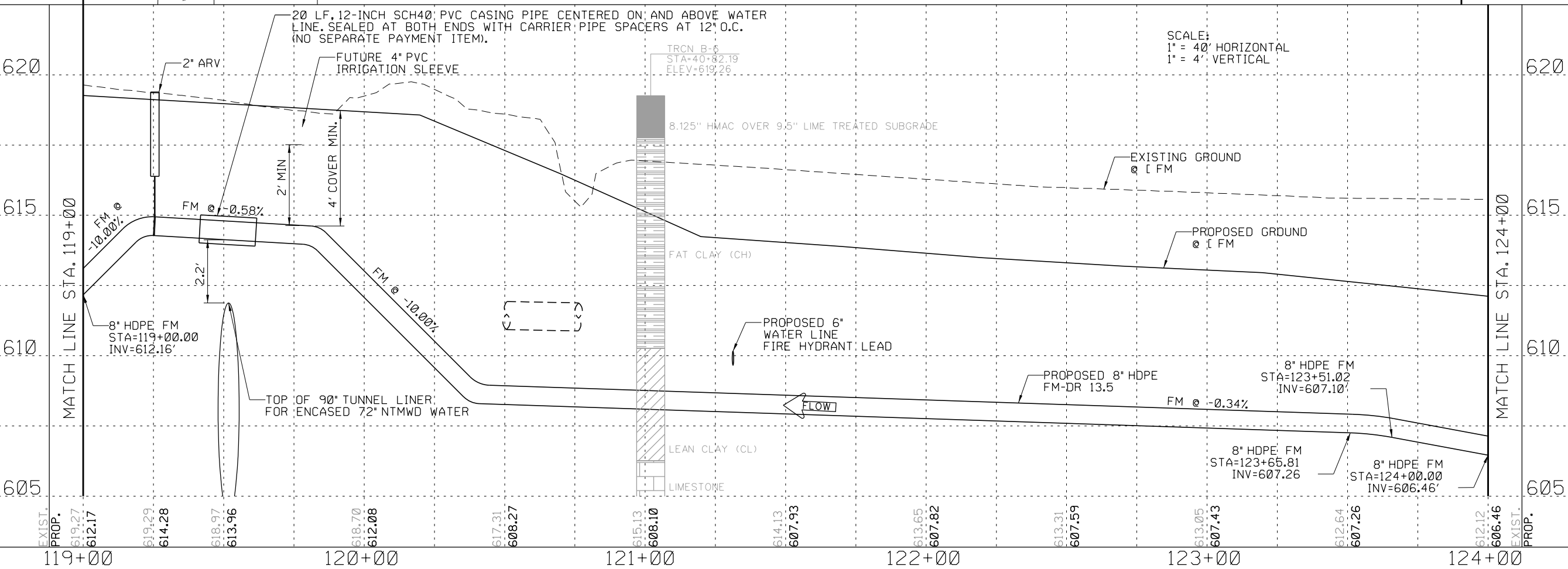

W. LUCAS RD.  
 ROADWAY  
 IMPROVEMENTS

FORCE MAIN  
 PLAN & PROFILE

SHEET 5 OF 12

MARK ROETZEL, P.E.  
 LIC. No. 57660  
 3400 WATERVIEW PKWY.  
 RICHARDSON, TX 75080  
 PHONE: 972.244.6000  
 TBPE REG. F-1481

REVISION 2: REMOVED TRENCHLESS NOTATIONS

**PARSONS**

CITY OF LUCAS  
 PUBLIC WORKS DEPARTMENT  
 665 COUNTRY CLUB ROAD  
 LUCAS, TX. 75002

JOB	ROAD	SHEET NO.
	W. LUCAS RD.	
COUNTY		219
COLLIN		

DATE: 6/18/2026 12:00:38 PM  
 FILE: I:\024793 West Lucas Road Design\_Revision\Design Data\4 - Design\Plan Set\14 - Force Main\Lucas\_FM\_PP08\_REV2.dgn

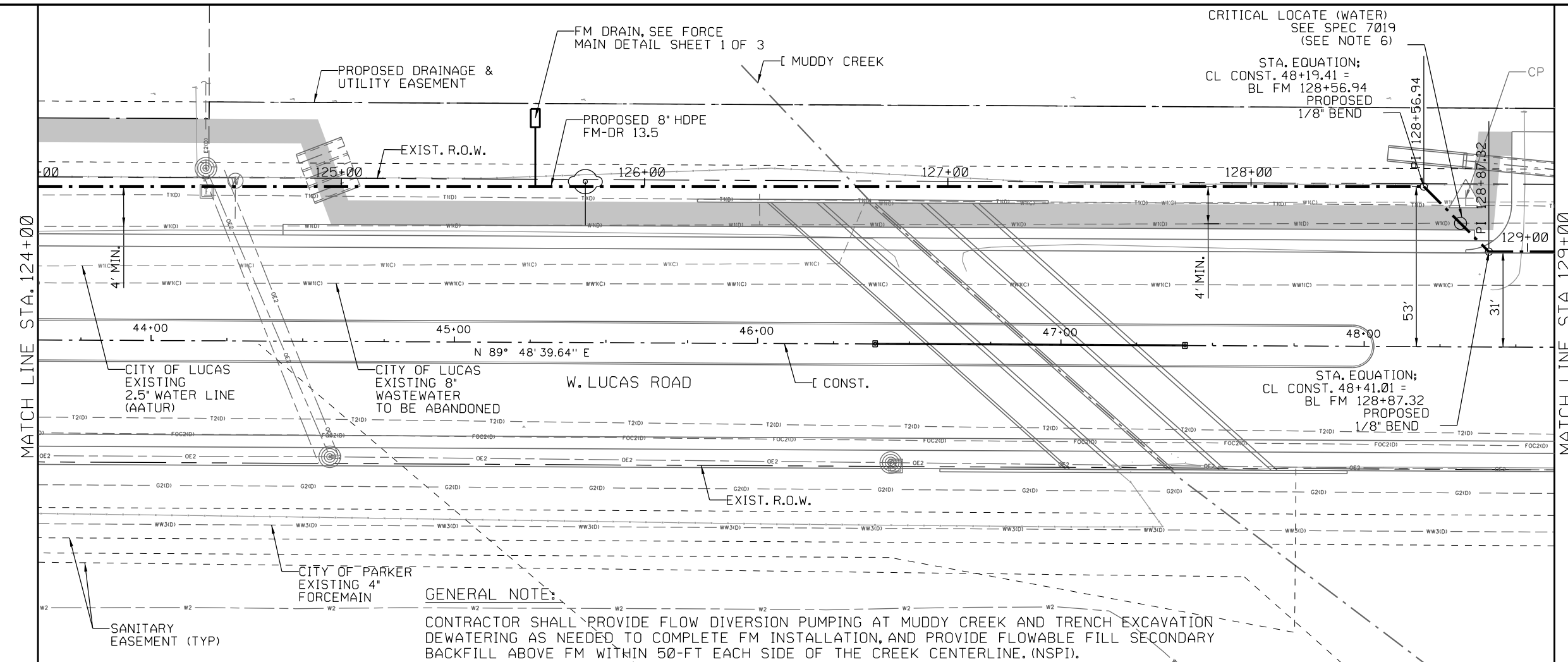

DATE: 6/18/2026 11:22:39 AM  
 FILE: I:\024793 West Lucas Road Design\_Revision\Design\_Data\4 - Design\Plan Set\14\_Force Main\Lucas\_FM\_Manhole\_details.01\_REV2.dgn

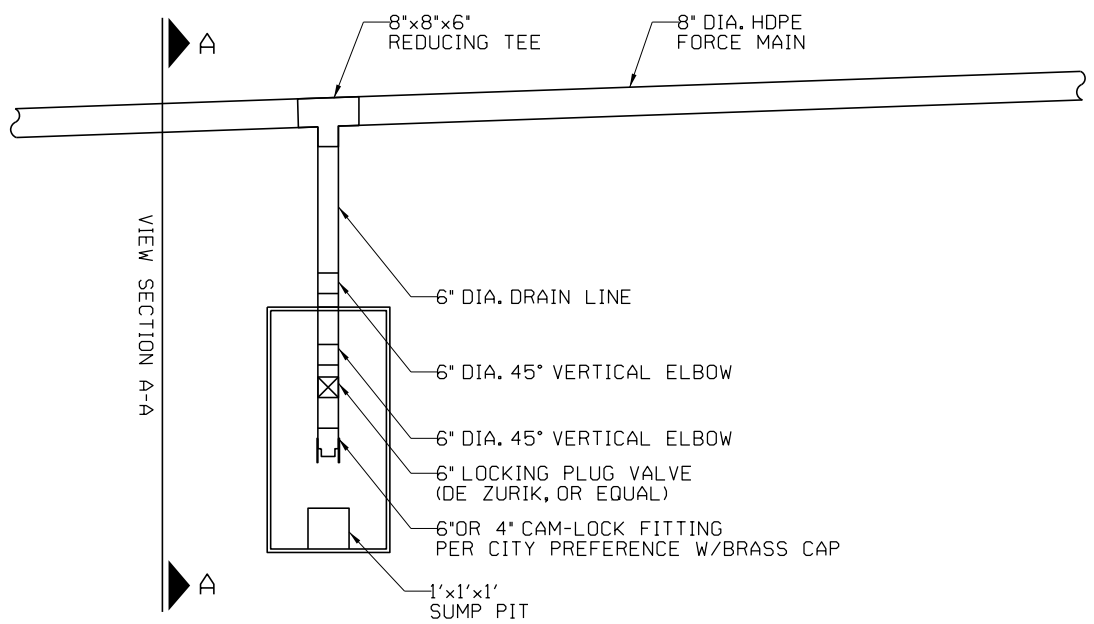

PLAN

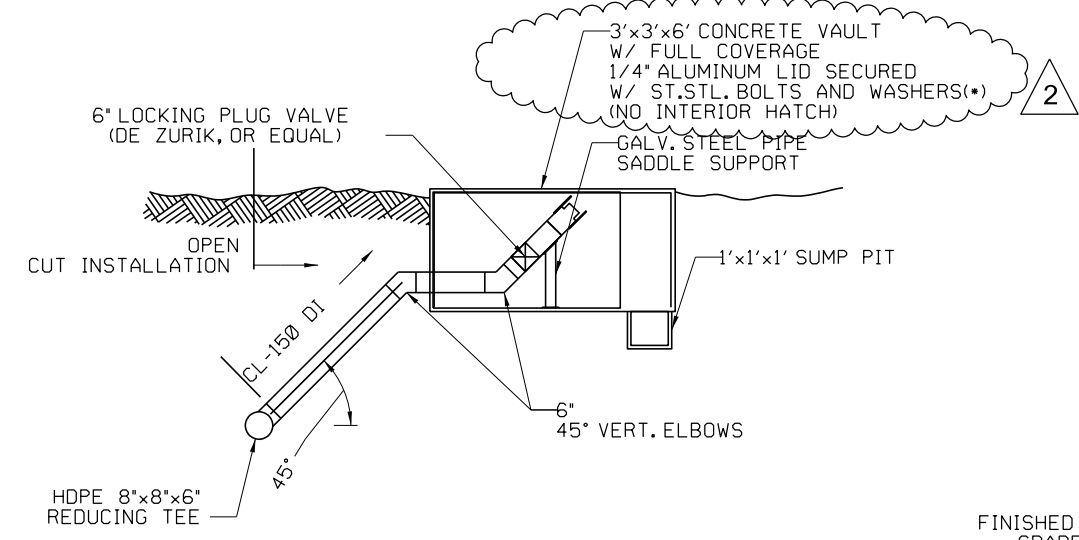

VIEW SECTION A-A

NOTE:  
 FORCE MAIN DRAIN LINE ASSEMBLY  
 WILL BE CONSIDERED INCIDENTAL  
 TO THE ASSOCIATED WORK (NSPI).

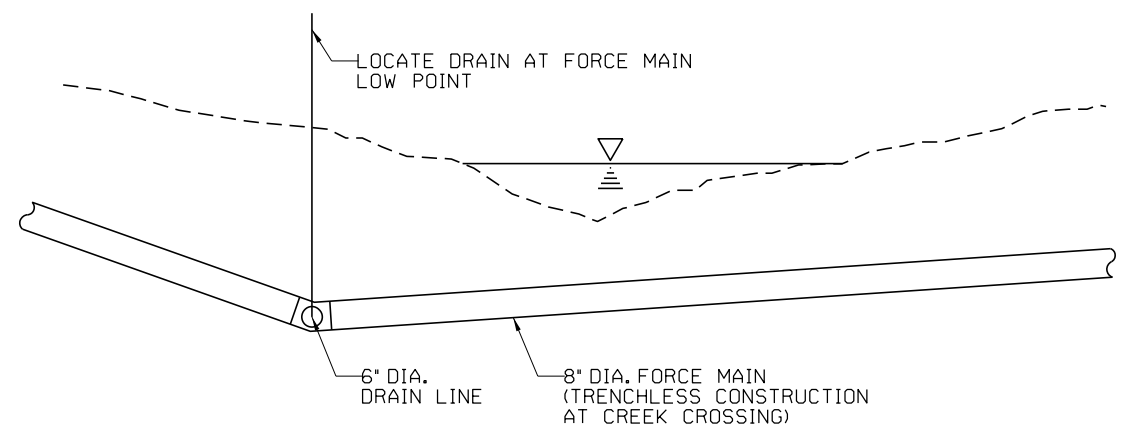

PROFILE

FORCE MAIN DRAIN DETAILS  
 NOT TO SCALE

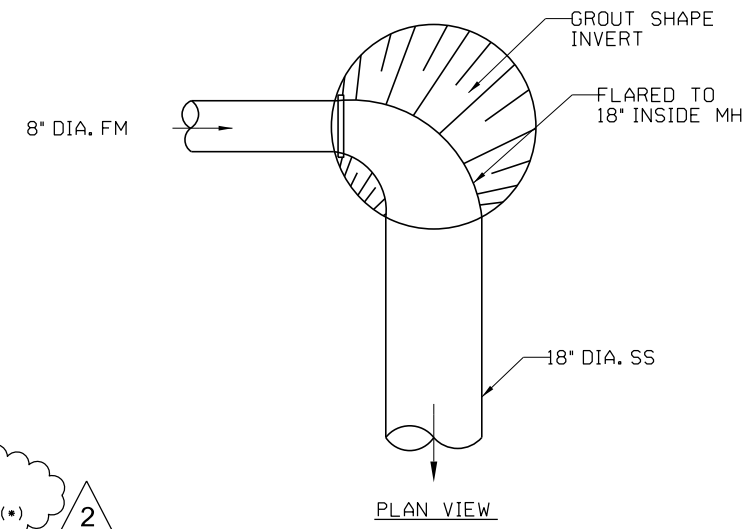

PLAN VIEW

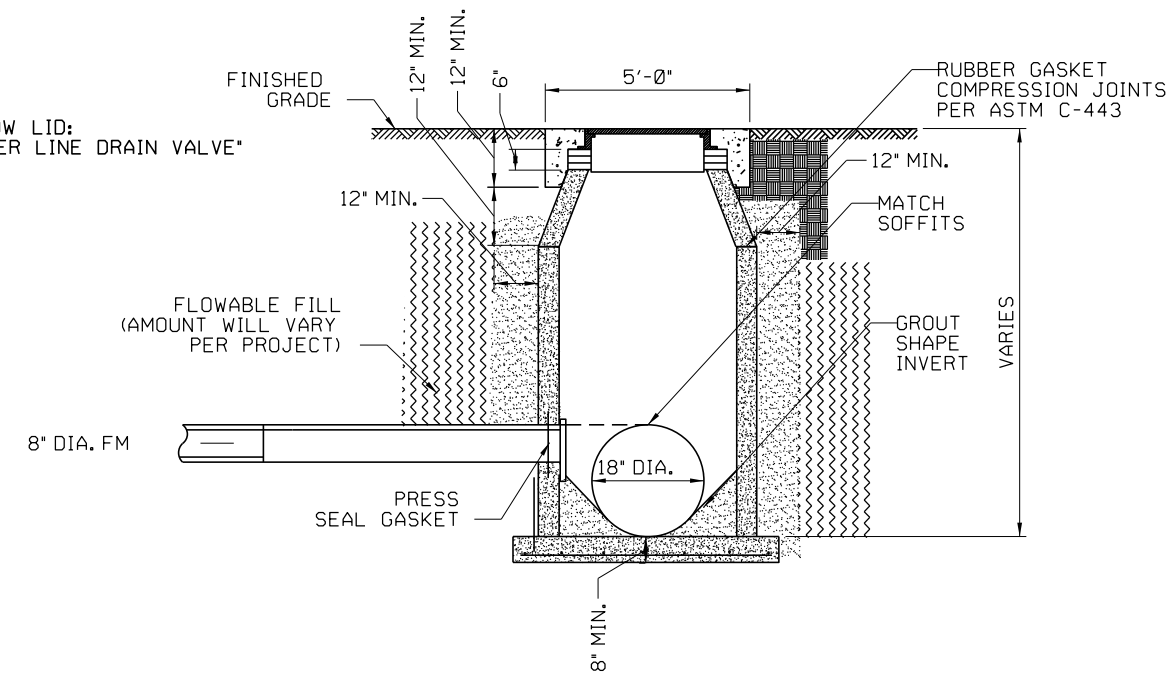

SECTION

TRANSITION MANHOLE DETAIL  
 NOT TO SCALE



W. LUCAS RD.  
 ROADWAY  
 IMPROVEMENTS

FORCE MAIN  
 DETAILS

SHEET 1 OF 3  
 MARK ROETZEL, P.E.  
 LIC. No. 57660  
 3400 WATERVIEW PKWY.  
 RICHARDSON, TX 75080  
 PHONE: 972.244.6000  
 TBPE REG. F-1481

REVISION 2: LABEL REVISED



CITY OF LUCAS  
 PUBLIC WORKS DEPARTMENT  
 665 COUNTRY CLUB ROAD  
 LUCAS, TX. 75002

JOB	ROAD	SHEET NO.
	W. LUCAS RD.	
COUNTY		227
COLLIN		

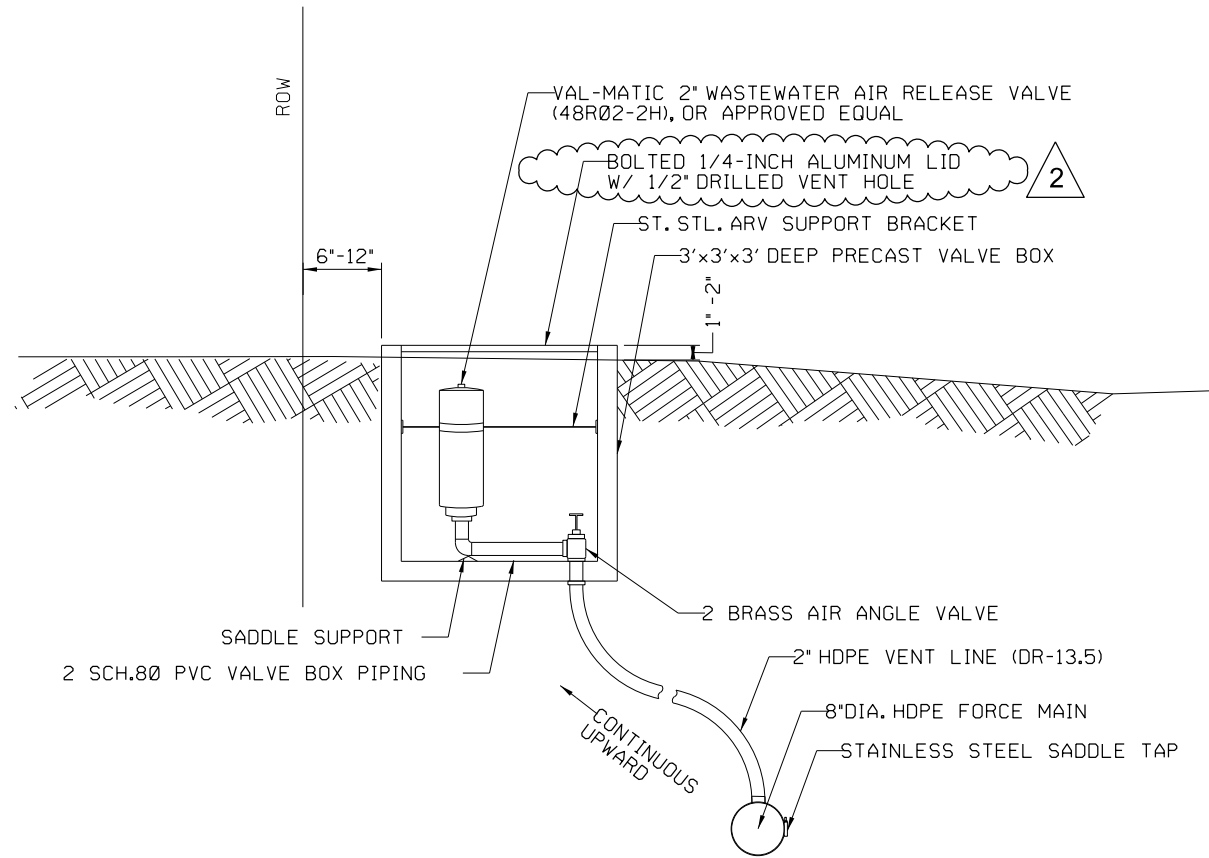

AIR RELEASE VALVE DETAIL  
NOT TO SCALE

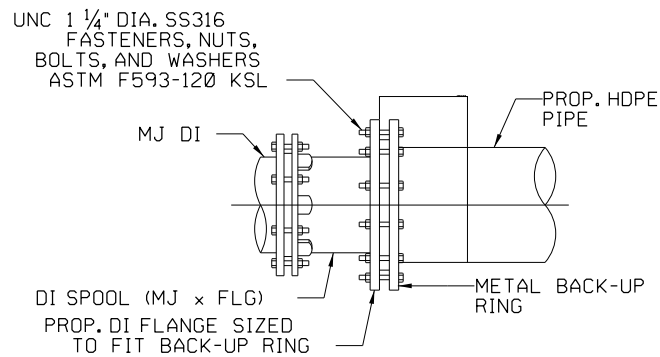

DUCTILE IRON TO HDPE DETAIL  
NOT TO SCALE

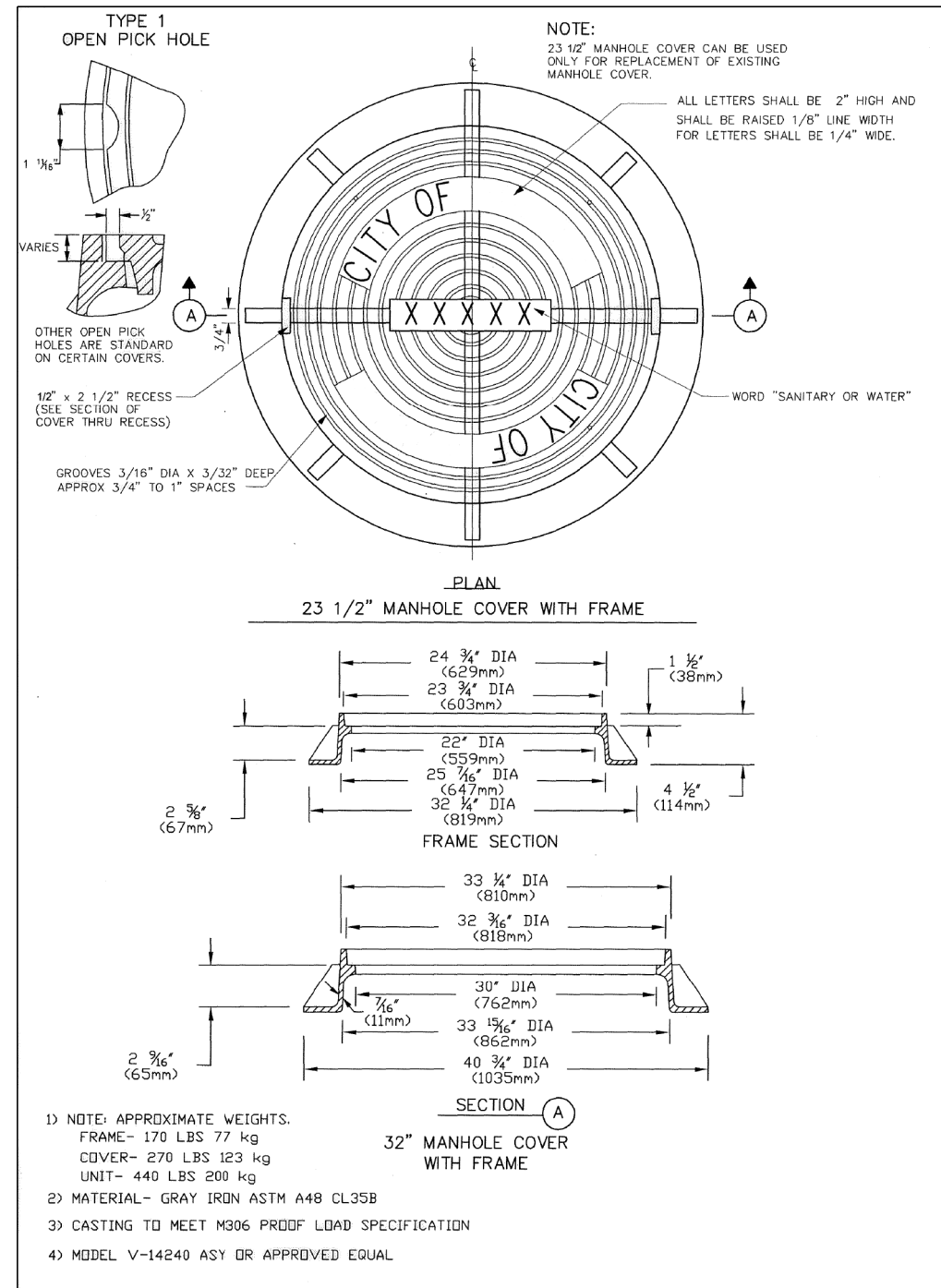

SANITARY SEWER AND WATER MANHOLE FRAME AND COVER  
NOT TO SCALE



W. LUCAS RD.  
ROADWAY  
IMPROVEMENTS

FORCE MAIN  
DETAILS

SHEET 2 OF 3

MARK ROETZEL, P.E.  
LIC. No. 57660  
3400 WATERVIEW PKWY.  
RICHARDSON, TX 75080  
PHONE: 972.244.6000  
TBPE REG. F-1481

REVISION 2: LABEL REVISED

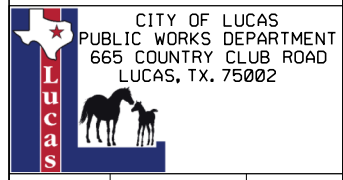

JOB	ROAD	SHEET NO.
	W. LUCAS RD.	
COUNTY		228
COLLIN		

DATE: 6/18/2026 11:19:50 AM  
 FILE: I:\024793 West Lucas Road Design\_Revision\Design\_Data\4 - Design\Plan Set\14\_Force Main\Lucas\_FM\_Manhole\_details\_02\_REV2.dgn

